VISTA

4140XMPT2

**PARTITIONED SECURITY SYSTEM
WITH SCHEDULING**

INSTALLATION INSTRUCTIONS



CONGRATULATIONS!

On Your Purchase Of The Ademco 4140XMPT2

The purpose of these Installation Instructions is to give you a complete overview of the system, and provide instructions for installing a basic system.

CONTACTING TECHNICAL SUPPORT

PLEASE,

Before you call Technical Support, be sure you:

- **READ THE INSTRUCTIONS!**
- **Check all wiring connections.**
- **Determine that the power supply and/or backup battery are supplying proper voltages.**
- **Verify your programming information where applicable.**
- **Note the proper model number of this product, and the version level (if known) along with any documentation that came with the product.**
- **Note your ADEMCO customer number and/or company name.**

Having this information handy will make it easier for us to serve you quickly and effectively.

You may contact Technical Support via Toll Free Fax. Please include your return fax number. You will receive a reply within 24 hours. You may also contact Technical Support via modem to ATLIS-BBS, Tech Support's Electronic Bulletin Board System. Replies are posted within 24 hours.

East Coast Technical Support: 1-800-645-7492 (8 a.m.-6 p.m. E.S.T.)

West Coast Technical Support: 1-800-458-9469 (8 a.m.-5 p.m. P.S.T.)

Technical Support Fax Number: 1-800-447-5086

ATLIS-BBS Electronic Bulletin Board System: 1-516-496-3980

(1200 - 9600 Baud, 8 Data Bits, 1 Start/Stop Bit, No Parity)

TABLE OF CONTENTS

Section 1. GENERAL INFORMATION.....		5
SUMMARY OF SYSTEM FEATURES.....		
General Information.....		5
System Features.....		6
Programming Features.....		7
Communication Features.....		7
INTRODUCTION TO THE PARTITIONED SYSTEM.....		
Introduction.....		8
Basic Partitioning Features.....		8
Examples Of Partitioning.....		9
Global Partitioning Features and Resources.....		9
Partition Specific Features.....		9
SCHEDULING OVERVIEW.....		
Major Features Of Scheduling.....		10
Access Door Control.....		10
Time-Driven Event Programming.....		10
End User Scheduling (#83 Menu Mode).....		10
Section 2. ZONE CONFIGURATIONS.....		11
ZONE TYPES & APPLICABLE SENSORS.....		
BASIC 9 HARD-WIRED ZONES.....		
Zone 1.....		13
Zone 9.....		13
Zones 2 - 8.....		14
2-WIRE POLLING LOOP EXPANSION (Zones 10 through 87).....		
General Information.....		15
Intercom Interference.....		15
Advisories.....		15
Important! Fault Annunciation.....		16
Compatible Polling Loop Devices.....		16
WIRELESS EXPANSION (Zones 1-63).....		
General Information.....		17
4280 Series Receiver.....		18
4281 Series Receiver.....		18
5881 Series Receiver.....		18
Transmitters.....		19
Wireless Zone Types.....		20
Advisories.....		20
Fault Annunciation.....		20
Important Battery Notice.....		21
Compatible 5700 Series Wireless Devices.....		21
Compatible 5800 Series Wireless Devices.....		22
VOLTAGE TRIGGERS (Connector J7).....		
General Information.....		23
Ground Start Module.....		23
Remote Keyswitch.....		24
Remote Console Sounder Operation.....		25
OUTPUT CONTROL (4204 Relay Module/X-10 Devices).....		
General Information.....		26
4204 Relay Module.....		26
4300 Transformer & X-10 Devices.....		26
Examples Of Uses For Relays.....		27
Section 3. REMOTE CONSOLES, SOUNDERS & PHONE CONNECTIONS.....		30
REMOTE CONSOLES.....		
General.....		30
4137AD.....		30
5137AD.....		30
6139.....		30
Programming The Consoles.....		31
Mounting The Consoles.....		31
Wiring Consoles.....		31
Powering Additional Consoles.....		31
EXTERNAL SOUNDERS.....		
Relay Output.....		32
UL Household Installations.....		32
Non-UL Installations.....		32
Compatible Sounders.....		32
PHONE CONNECTIONS.....		
		32

Section 4. MOUNTING THE CONTROL PC BOARD & LOCK	33
Mounting The 4140XMPT2 PC Board	33
Mounting The Cabinet Lock	33
Section 5. POWERING THE SYSTEM	34
Primary Power	34
Back-Up Power	34
Earth Ground Connections.....	34
Power-Up Procedure.....	34
SETTING THE REAL-TIME CLOCK.....	36
Section 6. SYSTEM OPERATION	38
SECURITY ACCESS CODES	37
General Information	37
User Codes & Levels Of Authority.....	37
Multiple Partition Access Examples	39
To ADD a Master, Manager or Operator code.....	40
To CHANGE a Master, Manager or Operator code	41
To Delete a Master, Manager or Operator code.....	41
To EXIT The User Code Entry Mode.....	41
KEYPAD FUNCTIONS	42
General Information	42
Arming Functions	42
Access Control.....	43
Delay closing window	43
Partition "Goto" Commands	43
View Capabilities Of A User	43
Viewing Downloaded Messages.....	43
Using The Built-In User's Manual	43
Displaying Descriptors	44
Panic Keys	44
Trouble Conditions.....	44
"Check" Messages	44
Other Trouble Conditions	44
Power Failure.....	44
Section 7. EVENT LOGGING & DIRECT WIRE DOWNLOADING	45
EVENT LOGGING	45
Event Logging Printer Connections.....	45
Event Logging Procedures.....	46
Programming.....	46
Event Logging Display & Print Modes	46
Clear Event Log	47
Screen Definitions.....	47
DIRECT WIRE DOWNLOADING.....	48
Section 8. SYSTEM COMMUNICATION	49
Split/Dual Reporting	49
Ademco Low Speed	49
Sescoa/Radionics	49
4+2 Reporting	49
4+2 Express.....	50
Ademco High Speed Reporting	50
Contact ID Reporting.....	51
Section 9. TESTING THE SYSTEM	52
Using Test Mode	52
Armed System Test	52
Turning The System Over To The User	53
Section 10. REGULATORY AGENCY STATEMENTS	54
DIP SWITCH TABLES.....	56
SUMMARY OF SYSTEM COMMANDS.....	59
Section 11. SPECIFICATIONS	60
SUMMARY OF CONNECTIONS DIAGRAM.....	61

Section 1. GENERAL INFORMATION

SUMMARY OF SYSTEM FEATURES

General Information The following table lists the major features of the 4140XMPT2 system.

NOTE: At least one 5137AD or 6139 addressable alpha display console must be used with this system.

System	The 4140XMPT2 Control is a microprocessor based, programmable, partitioned system, and features EEROM memory technology (power loss does not result in the loss of information).
Zones Supported	<ul style="list-style-type: none"> • Supports up to 9 traditional wired zones of protection. • Expandable to 87 zones (consisting of combinations of wired and/or wireless zones) using 2-wire polling loop devices, and/or 5700 or 5800 series wireless transmitters. • Zones can be distributed among up to 8 logical partitions of operation.
Fire Zones	<ul style="list-style-type: none"> • Supports up to sixteen 2-wire smoke detectors (zone 1). • Other zones can be fire zones using 4-wire smoke and heat detectors and/or polling loop detectors.
Output Control	<ul style="list-style-type: none"> • Supports up to 16 devices (4204 relay modules or X-10 devices). • These devices can be put under schedule control.
Remote Consoles	• Supports up to sixteen addressable remote consoles (6139, 5137AD, 4137AD).
Keyswitch	Supports the Ademco 4146 keyswitch.
Programming	<ul style="list-style-type: none"> • Programming can be performed at the office prior to installation, or on the job site directly from the console. • Can be downloaded from a remote location or at the job site (using a PC/laptop with 4100SM Serial Module) by using the Ademco 4130PC Downloading Software. • The Control is pre-programmed with a set of standard values that is designed to meet the needs of many installations. These values, however, can be changed to suit the needs of any particular installation. • The Control can also be pre-programmed by the installer with one of four standard communication default programming values, thus further saving time and effort.
User Codes	Supports up to 128 user codes, maximum of 99 per partition
Panic Keys	Provides 3 panic key functions.
Communication	Ademco low speed, SESCOA/RADIONICS, Ademco Express, Ademco High Speed, Ademco Contact ID

Before installing this partitioned system, become completely familiar with the partitioning concepts, including zone distribution (each zone can be assigned to only one partition), user code usage and authority levels, and the user-friendly menu mode of programming. In addition, become familiar with the scheduling and output relay features.

System Features

The following table lists the special system features of the 4140XMPT2 system.

Global Arming	<ul style="list-style-type: none">• Allows users to easily arm multiple partitions via console prompts.
Polling Loop	<ul style="list-style-type: none">• Built-in polling loop interface, with polling loop terminals located on the panel's terminal block, allows expansion up to 87 zones.
Glass Break Detector	<ul style="list-style-type: none">• Supports up to 50 latching type 2-wire glass break detectors on zone 8.
Quick Bypass (Forced Bypass)	<ul style="list-style-type: none">• Quick (forced) bypass feature bypasses all faulted zones with single key entry sequence.
Memory-Of-Alarm	<ul style="list-style-type: none">• Memory-of-alarm feature, which, upon disarming the system, automatically displays all zones that were in an alarm condition while the system was armed.
Circuit Breakers	<ul style="list-style-type: none">• Self resetting circuit breaker protection eliminates the need to replace blown cartridge fuses.
Built-in Users Manual	<ul style="list-style-type: none">• Built-in Users Manual (5137AD/6139 only). By depressing and holding any of the function keys on the console for 5 seconds, a brief explanation of that function scrolls across the alpha-numeric display.
Descriptors	<ul style="list-style-type: none">• All programmed descriptors can be displayed (one at a time) by pressing and holding the READY key for 5 seconds, then releasing the key. This serves as a check for installers to be sure all descriptors are entered properly.
Cabinet	<ul style="list-style-type: none">• Large cabinet with removable door for easier installations.
Scheduling	<ul style="list-style-type: none">• Scheduling feature allows installer and/or user to automate system operation and/or turn on lights, etc.• Auto-arm/disarm of system.• Temporary schedules can be programmed by user.• System operation can be restricted to certain times.
Wireless	<ul style="list-style-type: none">• Wireless support of 5700 or 5800 series transmitters using 4280, 4281 or 5881 type receivers.
Event Logging	<ul style="list-style-type: none">• Event Logging feature keeps record of all events, which can be printed automatically or on demand.
Access Control	<ul style="list-style-type: none">• Provides user activated access control command which pulses a relay output for controlled opening of access doors.

Programming Features

The following table lists the programming features of the 4140XMPT2 system.

User Codes	<ul style="list-style-type: none">• Up to 128 user security codes (max. 99 per partition) can be programmed, each with various levels of authority.
Installer Code	<ul style="list-style-type: none">• Installer code override feature. Installer code will disarm system only if it was used to arm the system.
Alpha Descriptors	<ul style="list-style-type: none">• All zones and partitions can be assigned alpha descriptions.• The letter "s" or " 's " can be added to descriptors.
Custom Words	<ul style="list-style-type: none">• Up to 20 custom words can be added to the built-in vocabulary.
Comm. Fields	<ul style="list-style-type: none">• Easy programming for communication fields. Simply enter the report code for each zone.
Comm. Defaults	<ul style="list-style-type: none">• Communication default programming can be loaded anytime, and does not affect non-communication program fields.
Downloading	<ul style="list-style-type: none">• Direct wire downloading can be done without a modem, by using a PC or Laptop computer and 4100SM Serial Module.
#93 Menu Mode	<ul style="list-style-type: none">• Easy programming of zones using the user friendly #93 Menu Mode.
Scheduling Menus	<ul style="list-style-type: none">• Easy scheduling programming using the #80 Menu Mode.

Communication Features

The following table lists the communication features of the 4140XMPT2 system.

Zone Reports	<ul style="list-style-type: none">• All 87 zones can report to a central station using any reporting format.
Exception Reporting	<ul style="list-style-type: none">• Open/close reporting by exception means reports occur only if outside predetermined time windows.
Callback	<ul style="list-style-type: none">• Callback defeat option for downloading.
Real-Time Clock	<ul style="list-style-type: none">• Real-Time clock for time related functions. NOTE: 5137AD or 6139 alpha console must be used to set the real-time clock, or can be set using Downloader software.
AC Loss Reporting	<ul style="list-style-type: none">• Random AC Loss and AC Restore reporting option sends report randomly from 10-40 minutes after AC loss, to help prevent central stations from receiving an overload of reports due to area blackouts.
Test Reporting	<ul style="list-style-type: none">• Intelligent test reporting option means test reports will not be sent if any other report was sent within the programmed test report interval.
Split/Dual Reporting	<ul style="list-style-type: none">• Split/Dual reporting communicator options available.
Cancel Report	<ul style="list-style-type: none">• Option to allow a cancel report to be sent, even after Bell Time-out has ended.
Voltage Triggers	<ul style="list-style-type: none">• Used to interface with LORRA or other devices.• PC Downloader can command output voltage triggers to pulse on for 2 seconds.
Phone Numbers	<ul style="list-style-type: none">• Primary and secondary phone number capability.• Can program different formats for each phone number.

UL NOTE: Downloading is not permissible for UL installations.

INTRODUCTION TO THE PARTITIONED SYSTEM

This section is intended to give you an overview of partitioning concepts. For specific questions on programming or using specific aspects of the panel, please refer to the SYSTEM OPERATION section of this manual and the PROGRAMMING GUIDE.

Introduction

The partitioned system represents the latest in security protection technology. Combining wired, wireless and polling loop zones into one powerful control, this control communicator is capable of supporting a true "partitioned" environment. A partitioned environment is one whereby multiple unrelated users wish to be protected by a security system, yet each user requires the operational freedom to have the system behave as if it was theirs and theirs alone. This global definition implies a lot of things in terms of the required features of the equipment you will install. Some basic features are listed below:

Basic Partitioning Features

The following table lists the partitioning features of the 4140XMPT2 system.

Simple	<ul style="list-style-type: none"> • Easy to use and program as the simplest alarm system.
Secure	<ul style="list-style-type: none"> • Integrity of security is not compromised for any users of the system.
Reliable	<ul style="list-style-type: none"> • Inherent reliability of the partitioned system is equal to a stand alone alarm system if purchased separately.
Consoles	<ul style="list-style-type: none"> • Flexible number of consoles per partition (up to a total of 16 in a system, anyway you want to assign them). • Appropriate sounds and messages to assigned consoles only (each system appears to be independent to users). • Ability to inhibit other consoles from using your partition (total security in a strip mall environment).
User Codes	<ul style="list-style-type: none"> • 128 User Codes assigned virtually anyway you want them (99 max. in any partition, otherwise no restrictions). Enough to handle the largest commercial jobs. • Multiple levels of authority per partition (allows key people in a partition to have complete control and limit system tampering by others).
Zones	<ul style="list-style-type: none"> • 87 zones employing wired, wireless or multiplex technology (install any mix for any type of construction challenges).
Partitions	<ul style="list-style-type: none"> • Any zone can be assigned to any particular partition (easy to install, allows logical assignment by the dealer). • "GOTO" function provides access to other partitions (ideal for executive access to factory for example). • Intelligent partition/zone menu programming help (simplifies the programming and reduces errors) • Programmable 4-character partition name displayed on alpha consoles when needed (no need to memorize numbers - name and number are shown for you).

Examples Of Partitioning

In surveying dealers throughout the country, we have learned of two global applications for partitioned control panels. One is a typical two family house (residential), the other a Factory/Office environment. These broad classifications can better be understood by way of examples.

Two Family House: You've just arrived at a job site to quote a security system. The owner wants an alarm system which he can use for his family (living upstairs) and he also wants to provide protection for the separate living quarters of his mother (living downstairs with separate entrance). The owner obviously wants to keep costs down yet provide protection and flexibility for his mother living downstairs. You could choose to install a traditional alarm panel to keep costs down, but the system would be very limiting for either the mother or the upstairs family. To meet the flexibility requirements as desired, you could install two traditional alarm panels, but the cost might cause you to lose the business. The 4140XMPT2 solves all these problems.

Factory/Office: You arrive at a small manufacturing concern looking to provide protection throughout their offices as well as their factory. The very nature of the business is such that factory workers come to work at 7:30AM and leave at 4PM, while the offices are open 8:30AM to 6:00PM. Some executives even want to stay late at night or come back to work after 6:00PM. Installing two panels (one for the factory, one for the offices) would certainly work at a cost premium, but think of all the complexity when owners tried to gain access to the factory after hours...two access codes to remember, accidental false alarms. Even the real frustration of not being able to properly program the two systems to allow easy access from the factory to office or vice versa! Install a partitioned system, your programming problems are over, and the owners of the business will appreciate its flexibility and ease of use!

Global Partitioning Features and Resources

In any system, certain physical system components and features are shared by all partitions or assigned to a specific partition. The following elements are shared or assignable to a specific partition:

	Shared By All Partitions	Assignable To One Partition
Dialer	✓	
Alarm Relay/Sounder	✓	✓ (using relay outputs)
Power Supply	✓	
Wireless Keypad		✓
Keyswitch Station		✓

In addition to the physical devices which are shared, the system shares some software features on a global basis as well. These include:

- Panic Code ReportsCommon code for any partition
- Low Battery ReportingReports as Partition 1
- AC Power Reporting OptionsReports as Partition 1
- Test Reporting IntervalGlobal for the Panel
- Download Phone NumberGlobal for the Panel
- Communication FormatGlobal for the Panel
- Rotary/Touch ToneGlobal for the Panel
- Download Callback defeatGlobal for the Panel
- Installer CodeGlobal for all Partitions

Partition Specific Features

Many devices and functions need to be reserved on a partition basis to provide proper operation and flexibility for installations. The items assignable on a per partition basis include:

- Consoles
- Entry and Exit Delays
- Console Sound during Exit Delay
- Primary Subscriber Number
- Secondary Subscriber Number
- Enable/Disable of Panic Keys
- Enable/Disable of Duress
- Multiple Alarm Reporting
- Quick Arm enable/disable
- Inhibit Bypass of one Zone
- Enable/Disable Chime Mode
- "Go To" Partition function
- Swinger Suppression
- Burglary Alarm Comm. Delay
- Open/close for Installer Code
- Confirmation of Arming Ding
- Alarm Sounder Duration
- User Codes

SCHEDULING OVERVIEW

Major Features Of Scheduling

Scheduling is an exciting new feature of the 4140XMPT2 and provides the following functions.

Arm/Disarm control

Scheduling can be used to automate some of the system operation:

- _ Auto arming and disarming at predetermined times.
- _ Auto-arm warning
- _ User option to delay auto arm
- _ Provision for temporary schedule of up to one week
- _ Provision for a holiday schedule
- _ Limitation of arming and disarming to specific times
- _ Control of when disarming will occur

Open/close by exception

Scheduling provides a means of reporting openings/closings by exception:

- _ sends report only if action does not occur.
- _ Inhibit opening/closing reports if within a Time Window
- _ Send early to open/close reports if done earlier than window
- Send late to open/close reports if window is missed.

Relay Control (Time Driven Events)

Scheduling can also automatically perform relay driven actions at predetermined times:

- _ Can turn lights or other devices on/off at specific times
- _ One shot action of light or other device
- _ X-10 control for the automation of lights and appliances

Daylight Savings Time

- _ Automatic time adjustment for daylight savings time

Scheduled events are programmed using a user friendly menu mode of programming (#80 mode), explained in detail in the separate PROGRAMMING GUIDE. This menu programming takes you step by step through the options. The following overview will give you an understanding of the scheduling concepts. Refer to the PROGRAMMING GUIDE for detailed programming instructions.

Access Door Control

The system also provides a means of access control. Entry of USER CODE + 0 will cause a momentary trigger of a pre-set output device. Each partition can have its own output device. The trigger will occur on the device tied to the partition for the console on which the keys were pressed. The access control relay is programmed in partition-specific field 1*76.

Time-Driven Event Programming

This very powerful feature allows arming, disarming, relay modules or X-10 devices to be activated automatically, based on the time windows described previously. Time driven events can also be used to assign additional open/close window schedules, so that more than one schedule per day can be programmed. The system supports up to 20 time driven events. Refer to the PROGRAMMING GUIDE—Scheduling Programming for more detailed information.

End User Scheduling (#83 Menu Mode)

The system provides up to 20 "timers" available to the end user for the purpose of activating output devices at preset times and on preset days. These timers are analogous to the individual appliance timers that might be purchased at a department store. The typical uses for this feature could be control of lights or appliances, typically via X-10 modules. These modules are programmed into the system by the installer during #93 Menu Mode—Device Programming. The end user needs only to know the output device number (relay number) and its alpha descriptor, both programmed by the installer via Relay Programming and Alpha Programming respectively. To enter this mode, the user enters CODE + # + 83.

The installer may set certain relays to be "Restricted", since a system may have some devices (Relays or X-10) which are not intended to be under the control of end users, such as relays activating fire doors or relays activating certain machinery. This option, set during #93 Menu Mode—Relay Programming, will restrict operation by the end user.

Section 2. ZONE CONFIGURATIONS

ZONE TYPES & APPLICABLE SENSORS

The 4140XMPT2 supports up to 87 zones of hard-wire, polling loop and/or wireless protection, distributed among up to 8 partitions. The following table lists the zone numbers and the types of sensors that can be used with each in this system:

Zone	Sensors
1	2-wire smoke detectors (if used)
7	keyswitch (if used)
8	latching type glass break detectors (if used)
1-9	traditional hard-wired zones
1-63	5700 series wireless devices
1-87	5800 series wireless devices
10-87	polling loop devices
95	*/1 panic
96	*/3 panic
99	*/# panic

Each zone must be assigned to a zone type, which defines the way in which the system responds to faults in that zone. In addition, there are three keypad activated zones (PANIC keys, see note below) for each partition, a polling loop supervision zone, and four RF supervisory zones, two for each RF Receiver installed. Zone types are defined below.

Type 00
Zone Not Used

Program a zone with this zone type if the zone is not used.

Type 01
Entry/Exit #1 Burglary.

This zone type provides entry delay whenever the zone is faulted if the control is armed in the Away or Stay modes. When the panel is armed in the Instant or Maximum modes, no entry delay is provided. Exit delay begins whenever the control is armed, regardless of the arming mode selected. These delays are programmable. This zone type is usually assigned to sensors or contacts on doors through which primary entry and exit will take place.

Type 02
Entry/Exit #2 Burglary.

This zone type provides a secondary entry delay whenever the zone is faulted if the panel is armed in the Away and Stay modes. When the panel is armed in the Instant or Maximum modes, no entry delay is provided. Secondary exit delay begins whenever the control is armed, regardless of the arming mode selected. These delays are programmable. This zone type is usually assigned to sensors or contacts on doors through which secondary entry and exit will take place, and where more time might be needed to get to and from the console. Delay time must be greater than Zone type 1. (Ex.: a garage, loading dock, or basement door)

Type 03
Perimeter Burglary.

This zone type gives an instant alarm if the zone is faulted when the panel is armed in the Away, Stay, Instant or Maximum modes. This zone type is usually assigned to all sensors or contacts on exterior doors and windows.

Type 04
Interior, Follower.

This zone type gives a delayed alarm (using the programmed Entry/exit time) if the Entry/Exit zone is faulted first. Otherwise this zone type gives an instant alarm. This zone type is active when the panel is armed in the Away or maximum modes. Maximum mode eliminates the delay though. **This zone type is bypassed automatically when the panel is armed in the Stay or Instant modes.** This zone type is usually assigned to a zone covering an area such as a foyer, lobby, or hallway through which one must pass upon entry (After faulting the entry/exit zone to reach the console to disarm the system.) Since this zone type is designed to provide an instant alarm if the entry/exit zone is not violated first, it will protect an area in the event an intruder hides on the premises prior to the system being armed, or gains access to the premises through an unprotected area.

Type 05
Trouble by Day/Alarm by Night.

This zone type will give an instant alarm if faulted when armed in the Away, Stay, Instant or Maximum (night) modes. During the disarmed state (day), the system will provide a latched trouble sounding from the console (and a central station report, if desired). This zone type is usually assigned to a zone which contains a foil-protected door or window (such as in a store), or to a zone covering a "sensitive" area such as a stock room, drug supply room, etc. This zone type can also be used on a sensor or contact in an area where immediate notification of an entry is desired.

Type 06
24-hour Silent Alarm.

This zone type sends a report to the Central Station but provides no console display or sounding. This zone type is usually assigned to a zone containing an Emergency button.

Type 07
24-hour Audible Alarm.

This zone type sends a report to the Central Station, and provides an alarm sound at the console, and an audible external alarm. This zone type is usually assigned to a zone that has an Emergency button.

Type 08
24-hour Auxiliary Alarm.

This zone type sends a report to Central Station and provides an alarm sound at the console. **(No bell output is provided)**. This zone type is usually assigned to a zone containing a button for use in personal emergencies, or to a zone containing monitoring devices such as water sensors, temperature sensors, etc.

Type 09
Supervised Fire. (No Verification)

This zone type provides a fire alarm on short circuit and a trouble condition on open circuit. The bell output will pulse when this zone type is faulted. This zone type is always active and cannot be bypassed. **This zone type can be assigned to any wired zone, but only certain wireless systems zones.**

Type 10
Interior w/Delay.

This zone type gives entry delay (using the programmed entry time), if tripped when the panel is armed in the Away mode. This zone type is also active during maximum mode, but no delay is provided (alarms occur immediately if zone is tripped). **This zone type is bypassed when the panel is armed in the Stay or Instant modes.** Delay begins whenever sensors in this zone are violated, regardless of whether or not an entry/exit delay zone was tripped first.

Type 20
Arm-Stay*

This is a special purpose zone type used with 5800 series wireless pushbutton or contact closure or opening, and which will result in arming the system in the STAY mode when the zone is activated.

Type 21
Arm-Away*

This is a special purpose zone type used with 5800 series wireless pushbutton or contact closure or opening, and which will result in arming the system in the AWAY mode when the zone is activated.

Type 22
Disarm*

This is a special purpose zone type used with 5800 series wireless pushbutton or contact closure or opening, and which will result in disarming the system when the zone is activated.

Type 23
No Alarm Response

This zone type can be used on a zone when an output relay action is desired, but with no accompanying alarm (ex. lobby door access).

* Note that these zone types are not for use by 5700 series devices.

NOTE FOR PANIC KEYS

Keypad panic zones share the same zone response type for all 8 partitions, but panics may be individually enabled for each partition.

IMPORTANT! FAULT ANNUNCIATION

Polling loop and RF faults (zones 88-91 & 97) will report as trouble conditions only, and as such, should be assigned either zone type 00 if no annunciation is desired, or zone type 05 if annunciation as trouble condition is desired. See FAULT ANNUNCIATION notes in POLLING LOOP and WIRELESS EXPANSION sections for more information.

BASIC 9 HARD-WIRED ZONES

Zone 1 The following table summarizes zone 1 characteristics.

Applications	Can be used for EOLR supervised or closed circuit unsupervised devices. It is the only zone that supports 2-wire smoke detectors.
Zone Response Type:	Any
Response Time	350 msec
Max. Zone Resistance	100 ohms, excluding EOLR
Unsupervised Usage	<ul style="list-style-type: none"> • Cut red PCB jumper. • Only closed circuit devices can be used.
EOLR Supervised	<ul style="list-style-type: none"> • Leave red PCB jumper intact. • Supports both open circuit and closed circuit devices. • Connect open circuit device in parallel across the loop. The 2,000 ohm EOLR must be connected across the loop wires at the last device. • Connect closed circuit device in series with the loop.
EOLR Fire Zone:	<ul style="list-style-type: none"> • Leave red PCB jumper intact. • Assign zone type 09 (fire) • Supports up to sixteen (16) 2-wire smoke detectors. • Second CODE + OFF sequence momentarily interrupts power to reset the smoke detectors. • See table below for compatible detectors.

Compatible Smoke Detectors

Detector Type	Device Model #
Photoelectric w/heat sensor, direct wire.....	System Sensor 2300T
Photoelectric, direct wire	System Sensor 2400
Photoelectric w/heat sensor, direct wire.....	System Sensor 2400TH
Photoelectric w/B401B base.....	System Sensor 2451
Photoelect. w/heat sensor & B401B base.....	System Sensor 2451TH
Ionization, direct wire	System Sensor 1400
Ionization w/B401B base	System Sensor 1451
Photoelectric duct detector w/DH400 base	System Sensor 2451
Ionization duct detect. w/DH400 base	System Sensor 1451DH

Zone 1 Advisories

If the EOLR is not at the end of the loop, the zone is not properly supervised. The system may not respond to an open circuit within the zone.

The alarm current provided by this zone is sufficient to support operation of only one detector in the alarmed state.

UL NOTE: EOLR are required for UL installations.

Zone 9 The following table summarizes zone 9 characteristics.

Applications	This zone is unsupervised and is suitable for monitoring fast acting glass break sensors or vibration sensors when programmed for fast response.
Response Type	Any type except fire
Response Time	Normal (350 msec) or Fast (10msec) selected in field *14.
Max. Zone Resistance	300 ohms
Unsupervised Usage	<ul style="list-style-type: none"> • Only closed circuit devices can be used. • Connect these devices in series with one another between terminals 22 & 23.

Zone 9 Advisories

Avoid using mechanical magnetic or relay type contacts in this zone when programmed for fast response.

UL NOTE: The interconnecting wires from zone 9 shall be no longer than 3 feet, with no intervening walls or barriers for UL installations.

Zones 2 - 8

The following table summarizes zones 2-8 characteristics.

Applications	Can be used for EOLR supervised or closed circuit un-supervised devices. Can also support 4-wire smoke detectors. Zone 8 can support latching glass break detectors.
Zone Response Type	Any
Response Time	350 msec
Max. Zone Resistance	<ul style="list-style-type: none"> • Zones 1-7: 300 ohms, excluding EOLR • Zone 8: 100 ohms, excluding EOLR
Unsupervised Usage	<ul style="list-style-type: none"> • EOLR disabled in field *41 (enter 1). • Only closed circuit devices can be used.
EOLR Supervised	<ul style="list-style-type: none"> • EOLR enabled in field *41 (enter 0). • Supports both open circuit and closed circuit devices. • Connect open circuit devices in parallel across the loop. The 2,000 ohm EOLR must be connected across the loop wires at the last device. • Connect closed circuit devices in series with the loop.
Glass Break Devices on Zone 8	<ul style="list-style-type: none"> • Supports up to 50 2-wire latching type glass break detectors. • Configure as EOLR zone • Second CODE + OFF sequence momentarily interrupts power to reset the glass break detectors. • See table below for compatible detectors.
Smoke Detectors on Zones 2-8	<ul style="list-style-type: none"> • Supports as many 4-wire smoke detectors as can be powered • Assign zone response type 09 (fire). • The zones must be configured for EOLR supervision. • A normally-closed, momentary switch must be installed in series with the power to the detectors in order to allow reset of the smoke detectors after an alarm. • The detectors must be wired in parallel, with the EOLR at the last detector for full supervision. • To supervise power, a System Sensor No. A77-716 EOL Relay Module is recommended.

Compatible Glass Break Detectors

Use detectors which are compatible with the following ratings:

Standby Voltage: 5VDC - 13.8VDC

Standby Resistance: Greater than 20k ohms (equivalent resistance of all detectors in parallel)

Alarm Resistance: Less than 1.1k ohms (see note below)

Alarm Current: 2 mA - 10 mA

Reset Time: Less than 6 seconds

The IEI 735L series detectors have been tested and found to be compatible with these ratings. Up to 50 IEI 735L detectors, connected in parallel, may be used (the alarm current provided by this zone is sufficient to support operation of only one detector in alarmed state). Follow the manufacturer's recommendations on proper installation.

Detectors which exceed 1.1k ohms in alarm, but maintain a voltage drop in alarm of less than 3.8 volts can also be used.

Zones 2-8 Advisories

If latching type devices are installed on both zones 1 & 8, and these zones are assigned to different partitions, there is a possibility that, if both devices go into alarm at the same time, the resetting of one device could cause the loss of alarm memory in the other device.

Use of N.O. or N.C. contacts on the same zone may prevent proper glass break detector operation.

UL NOTE: 4-wire smoke detectors cannot be used in UL installations.

2-WIRE POLLING LOOP EXPANSION (Zones 10 through 87)

General Information

The following table summarizes polling loop expansion characteristics.

Applications	<ul style="list-style-type: none"> Built-in 2-wire polling loop interface allows the number of zones to be expanded from the basic 9 zones to up to 87 zones using various Remote Point Modules (RPMs). See ADVISORIES below. The polling loop provides power to sensors and serves as communication path between the panel and sensors. Refer to the list of compatible devices at the end of this section.
RPM Address (ID)	<ul style="list-style-type: none"> Each sensor must be assigned a unique address ID number (from 10-87) before being connected to the polling loop. Care must be taken to assign unique ID numbers to each sensor in order to allow the panel to supervise and provide console status indications for individual sensors. Most RPMs have DIP switches to set their addresses. The 4139SN and 4191SN have preprogrammed serial numbers which must be "learned" by the control via the #93 menu programming mode.
Connections	<ul style="list-style-type: none"> Connect RPM sensors to terminals 24 & 25. Sensors can be connected to a single run, or groups of sensors may be connected to separate wire runs without affecting the panel's ability to supervise individual sensors. Follow the wiring instructions provided with individual sensors. Be sure to observe sensor polarity when wiring. The maximum allowable wire run length between the panel and the last sensor on a given wire run is shown in the table below.

Maximum Polling Loop Wire Runs

Wire Gauge	Max. Length
#22 gauge	650 feet
#20 gauge	950 feet
#18 gauge	1500 feet
#16 gauge	2400 feet

Note Twisted pair recommended for all normal wire runs.

IMPORTANT: The maximum combined polling loop run is 4000'. If using shielded wire, the maximum is 2000'. If longer wire runs are needed, a 4197 Loop Extender Module must be used (see instructions included with the 4197).

Intercom Interference

If an intercom system is being used, the polling loop wires must be as far from the intercom wiring as possible (minimum 6"). If this spacing cannot be achieved, shielded wire must be used. If this is not done, interference on the intercom system might occur. Also note that the maximum total wire length supported is cut in half when shielded wire is used.

Advisories

The built-in polling loop has two limitations that must be observed. First, the maximum allowable current draw from the polling loop is 64mA. Refer to the POLLING LOOP CURRENT DRAW WORKSHEET (found in the POWERING THE SYSTEM section of this manual) for current draws of various polling loop devices. Second, regardless of current draw, no more than 64 devices can be connected to this loop. Installations which require up to 87 zones will require the use of 4190WH RPMs (which offer 2-points – a right and a left loop – per device) or the use of a 4197 (which offers another polling loop supporting an additional 64mA/64 points)

Make certain to include the total current drawn on the polling loop in the AUXILIARY CURRENT DRAW WORKSHEET (see POWERING THE SYSTEM section) when figuring the total auxiliary load on the panel's power supply.

Important! Fault Annunciation

Since the polling loop and the RF receiver(s) are shared among the 8 partitions, the scheme for annunciating their failure is as follows:

Respective faults (for zones 88-91 & 97) will report as trouble conditions only, and as such, should be assigned either zone type 00 if no annunciation is desired, or zone type 05 if annunciation as trouble condition is desired. If the polling loop or RF link fails, the corresponding zone number will display a trouble condition for each partition that uses the device that failed. In addition, all zones associated with that device will indicate a fault condition. The trouble condition will not interfere with the ability to arm the partition, but the faults must first be bypassed.

Compatible Polling Loop Devices

4208 Eight Zone Polling Loop Expansion Module

- Used to supervise up to 8 hard-wired devices via the polling loop. NOTE: Does not support 2-wire smoke detectors.
- Set DIP switches to identify 8 zones.
- The first two zones can be either normal or fast response (DIP switch selectable).
- All zones are EOLR supervised (first six zones = 4.7k ohms, last two zones = 30k ohms), provided with the 4208.

4190WH Two Zone Remote Point Module

- Used to supervise 2 hard-wired devices via the polling loop.
- DIP switch programmable.
- The left zone can be EOLR supervised, if necessary, and can accept either open or closed circuit sensors, and can be set for fast response. The right zone is unsupervised and can accept closed circuit sensors only.

4278 Quad Element Polling Loop PIR

- Quad element PIR with built-in RPM which is DIP switch programmable and connects directly to the polling loop. Includes mirrors for both wide angle and curtain/long range applications. Features an auxiliary sensor loop that permits connection of another nearby closed circuit alarm sensor (reed contact, etc.).

4275 Dual Element Polling Loop PIR

- Dual element PIR with built-in RPM which is DIP switch programmable. Includes mirrors for both wide angle and curtain/long range applications and can use the 1875PA Pet Alley mirror. Built-in selectable pulse count capability.

4194 Surface Mounted Reed Contact (Wide Gap)

- Wide gap surface mounted reed contact with built-in RPM, which is DIP switch programmable.

4197 Polling Loop Extender Module

- Can be used if the 2-wire polling loop must be greater than the recommended length (4000' max). By installing a 4197 at the end of the first loop, the polling loop can be continued. If more than 64mA needs to be drawn from the polling loop to power RPMs, use of the 4197 provides another loop with 64mA available.
- Connects to the polling loop and is powered from auxiliary power or by a separate 729 power supply with battery backup.

4192SD Photoelectric Polling Loop Smoke Detector

- One piece photoelectric smoke detector with built-in RPM which is DIP switch programmable.

4192SDT Photoelectric Polling Loop Smoke Detector w/Heat Detector

- One piece photoelectric smoke detector with 135°F (57°C) heat detector, and built-in RPM which is DIP switch programmable.

4192CP Ionization Smoke Detector

- One piece products of combustion ionization detector with built-in RPM which is DIP switch programmable.

4139SN Auto Smart Surface Mount Reed Contact

- Compact surface mount magnetic reed contact with built-in RPM.
- Serial number ID "learned" by control panel.
- Check product availability.

4191SN Auto Smart Recessed Reed Contact

- Recessed (1/2" dia.) magnetic reed contact with built-in RPM.
- Serial number ID "learned" by control panel.
- Check product availability.

WIRELESS EXPANSION (Zones 1-63)

General Information (Receivers)

The following table summarizes wireless expansion characteristics.

Transmitters Supported by various receivers

Receiver	Transmitter
4280	63
4280-8	8
4281H	63
4281M	8
4281L	4
5881H	64
5881M	16
5881L	8

Zones Supported	<ul style="list-style-type: none"> The system supports up to 63 wireless transmitters (5700 or 5800 series), plus a wireless keypad. To expand the system using wireless, one or two of the same type of RF Receivers can be used. Any zone from 1-63 can be used as a 5700 series wireless zone. The total number of transmitters supported by each receiver is shown in the transmitters supported table. Any zone from 1-87 can be used as a 5800 series wireless zone.
RF Receivers (General)	<ul style="list-style-type: none"> The 4140XMPT2 supports the 4280, 4281 and 5881 series RF receivers. Refer to the transmitters supported table for the number of zones supported by each receiver. The receivers respond to status and alarm signals from wireless transmitters (@345MHz USA; 315MHz Canada) within a nominal range of 200 feet, and relay this information to the control. Two of the same type of receivers can be used to provide either a greater area of coverage, or to provide redundant protection. The type of receiver used is identified in program field 1*32. Receivers must be mounted externally to the control. The 4280 & 4280-8 receivers are connected to the polling loop. The 4281 and 5881 series receivers are connected to the console data lines.
Receiver Supervision	<ul style="list-style-type: none"> If the connection is broken between the receiver and the control panel, a TROUBLE will be displayed for zones 89 or 91 (if type 05 is assigned). In addition, all zones associated with the RF device will report a trouble condition. If, within a programmed interval of time, the receiver does not hear from <i>any</i> of its transmitters, a TROUBLE will appear for zones 88 or 90 (if type 05 is assigned). 4280 only: If the cover of the 4280 is removed, a TROUBLE will be displayed for zones 89 or 91 (if type 05 is assigned).
House Identification	<ul style="list-style-type: none"> Receivers respond only to transmitters set to the same house ID (01-31). This prevents system interference from transmitters in other nearby systems. Use Sniffer Mode (described later) to make sure you do not choose a House ID that is in use in a nearby system. 4280 house ID is set via DIP switches. 4281/5881 (for 5827) house ID is programmed via #93 Menu Mode, Device Programming.
Sniffer Mode For House Id (Code + [#] + [2])	<ul style="list-style-type: none"> To check for house IDs being used in nearby systems, set the receiver's House ID to "00", then enter your "Installer Code" + [#] + [2] The receiver will now "sniff" out any House IDs in the area and display them. Keeping the receiver in this mode for about 2 hours will give a good indication of the house IDs being used. To exit the Sniffer Mode, simply key your installer code + OFF, then set your house ID to one not displayed in the "Sniffer Mode". Important: Since Sniffer Mode effectively disables RF point reception, Sniffer Mode cannot be entered while any partition is armed.

The following table highlights the features of each receiver.

FEATURE	4280 series	4281 series	5881 series
Wiring	Connects to polling loop	Connects to console lines	Connects to console lines
House ID	set via DIP switches	programmed via #93 Menu Mode.	programmed via #93 Menu Mode.
Receiver Address	Set by cutting blue jumper in 2nd receiver. Enabled via fields 1*26 & 1*27.	Set via DIP switches. Enabled via #93 Device Programming.	Set via DIP switches. Enabled via #93 Device Programming.
Cover Removal	Causes alarm or trouble depending on response type assigned.	Does not cause alarm or trouble.	Does not cause alarm or trouble.
Go/No Go Mode	Requires cover removal.	Automatic upon entering test mode.	Automatic upon entering test mode.
Spatial Diversity	No. Requires 2 receivers for redundancy or to expand area of coverage.	Yes. Eliminates nulls and voids. 2nd receiver expands coverage area or provides additional redundancy.	Yes. Eliminates nulls and voids. 2nd receiver expands coverage area or provides additional redundancy.
Transmitter ID	Set via DIP switches.	Set via DIP switches.	Serial numbers are "learned" by the system.

4280 Series Receiver

4280 is not recommended for new installation; receiver is scheduled to be discontinued.

- **Important:** Note that if using two RF Receivers, one of them must be powered from auxiliary power, so as not to exceed the 64mA polling loop current rating.
- Set field 1*32 to 0.
- For more information regarding the 4280 installation, refer to the installation instructions provided with the 4280.
- If using a 4280-8, only up to 8 zones can be enabled as RF zones. If more than 8 zones are enabled, the message "SET-UP ERROR" (or E8 on non-alpha consoles) will be displayed.
- Refer to the maximum polling loop wire runs described in the POLLING LOOP section when connecting 4280s to the polling loop.
- **IMPORTANT:** The maximum combined polling loop run is 4000'. If using shielded wire, the maximum is 2000'.

4281 Series Receiver

- Set field 1*32 to 1.
- Using #93 Menu mode—Device Programming, select as RF device type.
- Set house ID via #93 Menu Mode.
- Set receiver's device address using its DIP switches. Lower numbered address is primary receiver (supervisory fault ID 90, 91). Higher numbered address is secondary receiver (receiver fault ID 88, 89).
- **Important:** 4281 microprocessor must have part number N5334Vx, where x is any number. The microprocessor is located just above the DIP switch on the PC board.

5881 Series Receiver

- Set field 1*32 to 2.
- Using #93 Menu mode—Device Programming, select as RF device type.
- Set house ID via #93 Menu Mode (needed for 5827 keypad only).
- Set receiver's device address using its DIP switches. Lower numbered address is primary receiver (supervisory fault ID 90, 91). Higher numbered address is secondary receiver (receiver fault ID 88, 89).

Transmitters

The following table summarizes wireless transmitter characteristics.

NOTE: After replacing a low or dead battery, activate the transmitter and enter the security code + OFF to clear its memory of the "Low Battery" signal.

Transmitters (General)	<ul style="list-style-type: none"> • Supports 5700 or 5800 series transmitters. • Each transmitter has its own unique transmitter ID number (Zone #). 5700 series transmitters use DIP switches to set the ID. 5800 series transmitters must have their ID numbers "learned" by the system. • 5700 series transmitters and the 5827 keypad must also be set for a house ID. Other 5800 series transmitters have built-in serial numbers and do not require a house ID to be set. After installation, check that all transmitters have been assigned the proper house ID by using the procedure described later.
Trans. Supervision	<ul style="list-style-type: none"> • Each transmitter (except 5701, 5727, 5802, 5802CP & 5803) is supervised by a check-in signal that is sent to the receiver at 70-90 minute intervals. If at least one Check-in is not received from a transmitter within a programmed interval (field 1*31), the console will display the transmitter number and "CHECK" will be displayed. • Each transmitter (including 5701; 5727, 5802, 5802CP & 5803) is also supervised for low battery conditions, and will transmit a low battery signal to the receiver when the battery has approximately 30 days of life remaining. The console will display the transmitter number and "LO BAT".
5800 Series "Learn"	<ul style="list-style-type: none"> • 5800 series transmitters have built-in serial numbers that must be "learned" by the system during programming. Refer to the PROGRAMMING GUIDE for details.
Checking Trans. Operation including DIP & serial number (Code + [#] + [3])	<ul style="list-style-type: none"> • To check that all transmitters have been set properly, set the receiver to the proper house ID and enter the Installer code + [#] + [3]. • All transmitters that have been enabled for the partition in which the test was initiated will be displayed. As each transmitter checks in (up to 2 hours), its ID number will disappear. A faster way to do this is to fault each transmitter, which causes a transmission to be sent to the receiver. When all transmitters have checked in, there should be no ID numbers displayed. • NOTE: Repeat this procedure for each partition that uses RF transmitters.
"Go/No Go" Test Mode (Patented)	<ul style="list-style-type: none"> • This mode helps determine the best location for each transmitter and is activated by putting the control panel in the TEST mode (4280 requires removing the its cover). • The receiver's sensitivity is reduced by half. Once transmitters are placed in their desired locations and the approximate length of wire to be run to sensors is connected to the transmitter's screw terminals, open circuit each transmitter. <i>Do not conduct this test with your hand wrapped around the transmitter.</i> • If a single receiver is used, the console will beep three times to indicate signal reception. If two receivers are used, the console will beep once if the first receiver received the signal, twice if the second receiver received the signal and three times if both receivers heard the signal (which is desirable for redundant configurations). • If the console does not beep, reorient or move the transmitter to another location. Usually a few inches in either direction is all that is required. • To exit this mode, enter the installer code and press OFF (replace the 4280's cover). Note that the Receiver's sensitivity is fully restored when this mode is exited.

**Note On RF Keys
(5801, 5803, etc.)**

5800 series RF keys can be used to arm and disarm the system. These transmitters include the 5801, 5803, and any other 5800 series transmitter if programmed for one of zone type responses 20-22. These transmitters are tied to a user in order to provide a record of who armed or disarmed the system. Because of this, an RF button will not arm or disarm a system unless it has been assigned to a user, which is done during the "add a user" function (see Add A User Code section). In addition, when the user is deleted from the system, the key is deactivated. To test whether the keys are assigned to users or not, use the test mode. When the appropriate button is pressed, the corresponding zone will be displayed on the console and will remain there until test mode is terminated.

Wireless Zone Types

Each RF zone can be programmed to respond as any zone type such as ENTRY/EXIT, INTERIOR, PERIMETER, etc. (see the ZONE TYPES section for a complete explanation of each zone type).

Desired alarm responses for 5700 series devices are as follows:

ZONE TYPE	TRANSMITTER ID #
Entry/Exit Burg	1 through 47 *
Perimeter Burg	1 through 47 *
Interior Burg	1 through 47 * 32 through 47 * (5775)
Fire	48 through 63 * 48 through 55 ** (5706)
24 Hour Panic (silent or audible)	48 through 63* 62 or 63 *** (5701)
Day/Night Burglary	1 through 47 *
24 Hour Auxiliary	1 through 47 *

NOTES:

- * Note that zones 1-63 can be used, but have the following limitations: Transmitters set for zones 48-55 will transmit once every 12 seconds while the zone is faulted. Transmitters set for zones 56-63 will transmit once every 3 seconds while faulted. These two ranges of zone numbers could adversely affect transmitter battery life. Transmitters set for an ID of 32 through 47 will have a 3 minute lock-out between transmissions. Use this last range of zone ID numbers for sensors protecting frequently used doors or windows to conserve battery life.
- ** Transmitter IDs 48 through 55 have highest signal priority.
- *** Transmitter IDs 62 and 63 are unsupervised to allow removal of the 5701 off premises -- signal priority is lower than that of fire, but higher than burglary.

Advisories

1. Do not place transmitters on or near metal objects. This will decrease range and/or block transmissions.
2. Place the receiver in a high, centrally located area for best reception. Do not place receiver on or near metal objects.
3. For maximum range, the RF receiver must be at least 10 feet from the Control panel or any remote consoles to avoid interference from their microprocessor.
UL NOTE: For UL Household Burglary Installations, wired loops connected to these devices cannot exceed 3 feet.
4. If dual receivers are used:
 - A. Both must be at least 10 feet from each other, as well as from the Control panel and remote consoles.
 - B. The house IDs must be the same.
 - C. Using two Receivers *does not* increase the number of transmitters the system can support (63 transmitters, plus a wireless keypad).

Fault Annunciation

Since the polling loop and the RF receiver(s) are shared among the 8 partitions, the scheme for annunciating their failure is as follows:

Respective faults (for zones 88-91 & 97) will report as trouble conditions only, and as such, should be assigned either zone type 00 if no annunciation is desired, or zone type 05 if annunciation as trouble condition is desired. If the polling loop or RF link fails, the corresponding zone number will display a trouble condition for each partition that uses the device that failed. In addition, all zones associated with that device will indicate a fault condition. The trouble condition will not interfere with the ability to arm the partition, but the faults must first be bypassed.

NOTE: 5800 series transmitters have built-in tamper protection and will annunciate as a "CHECK" condition unless field *24 is disabled.

Important Battery Notice

The wireless transmitters are designed to provide long battery life under normal operating conditions. Longevity of batteries may be as much as 4-7 years depending on the environment, usage, and the specific wireless device being used. External factors such as humidity, high or low temperatures, as well as large swings in temperature may all reduce the actual battery life in a given installation. The wireless system can identify a true low battery situation, thus allowing the dealer or user of the system time to arrange a change of battery and maintain protection for that given point within the system.

Button type transmitters should be periodically tested by the installer for battery life (5701, 5802, 5802CP & 5803).

Compatible 5700 Series Wireless Devices

- 5701**
Panic Transmitter

 - Programmable for either silent or audible 24 hour alarm (can be DIP switch programmed for zones 62 or 63).
- 5711**
Slimline Door/Window Transmitter

 - Can be used with any closed circuit sensor. Can be used on any zone 1-63 but, if set for zones 32-47, there will be a 3 minute lock-out between transmissions.
- 5711WM**
Door/Window Transmitter w/Reed Switch

 - Slimline door/window transmitter with built-in reed switch (magnet included). Can be used with any closed circuit sensor. Can be used on any zone 1-63 but, if set for zones 32-47, there will be a 3 minute lock-out between transmissions.
- 5715WH**
Universal Transmitter

 - DIP switch selectable for fast response, open or closed circuit sensor usage, and has a tamper protected cover. Use in applications where open circuit heat detectors are needed or where fast response devices are needed. Can be used on any zone 1-63 but, if set for zones 32-47, there will be a 3 minute lock-out between transmissions.
- 5727**
Wireless Keypad

 - Wireless keypad that can be used to turn the burglary protection on and off, and features the same built-in panic functions as wired consoles for either silent or audible 24 hour alarm. An LED indication lights each time a key is pressed to verify transmission (LED located in the [Q] READY key).
 - The keypad is identified as zone "00" when it transmits low battery messages. The keypad panics are identified in the same way as wired console keypad panics (i.e. 95, 96 & 99).
- 5716**
Door/Window Transmitter

 - Can be used with any open or closed circuit sensor (DIP switch selectable), and features a built-in reed switch. Can be used on any zone 1-63 but, if set for zones 32-47, there will be a 3 minute lock-out between transmissions.
- 5775**
Wireless PIR

 - The 5775 is a battery operated, wireless, dual element passive infrared motion detector with built-in selectable pulse count, that can be monitored by a 4280 (4280-8) wireless receiver, and is DIP switch programmable for zones 32-47. NOTE: There is a 3 minute lock-out between transmissions to preserve battery life.
- 5706**
Wireless Photoelectric Smoke Detector (System Sensor)

 - One piece smoke detector with built-in transmitter (DIP switch programmable for zones 48-55). Built-in UL Listed 85 dB piezoelectric alarm sounder and audible low battery warning.
- 5707**
Wireless Photoelectric Smoke Detector (ESL)

 - One piece, dual battery smoke detector with built-in transmitter (DIP switch programmable for zones 48-55). Built-in UL Listed 85 dB piezoelectric alarm sounder and audible low battery warning.

Compatible 5800 Series Wireless Devices

- | | |
|---|--|
| 5801
4-Button Transmitter | <ul style="list-style-type: none">• Four button hand held or wall mount transmitter.• Programmable functions• Includes one 466 battery |
| 5802
Pendant Panic Transmitter | <ul style="list-style-type: none">• Single button action• Press and hold to avoid accidental alarms• waterproof (sealed battery) |
| 5802CP
Belt Clip Panic Transmitter | <ul style="list-style-type: none">• Single button action• Press and hold to avoid accidental alarms• waterproof (sealed battery) |
| 5803
3-Button Transmitter | <ul style="list-style-type: none">• Three button "key"• Programmable functions• Sealed battery |
| 5806
Photoelectric Smoke Detector | <ul style="list-style-type: none">• Includes two 9 volt alkaline batteries (464)• Optional tamper protection |
| 5807
Photoelectric Smoke Detector | <ul style="list-style-type: none">• Includes two 9 volt alkaline batteries (464) |
| 5816
Miniature Transmitter | <ul style="list-style-type: none">• NO/NC capability• Built-in reed contact• Tamper• Includes one 3 volt lithium battery (466) |
| 5817
3-Point Transmitter | <ul style="list-style-type: none">• Accepts 3 switches with 3 different addresses• NO/NC capability• Tamper• Includes one 3 volt lithium battery (466) |
| 5827
Wireless Keypad | <ul style="list-style-type: none">• Use handheld or wall mounted• Provides almost complete system control capability• Raised dome keys and led for positive operation• No. 5634 belt clip available• Includes one 9 volt battery (464) |
| 5849
Glass Break Detector | <ul style="list-style-type: none">• Audio discriminator plus shock sensor• Tamper• Includes two 3 volt lithium batteries (466) |
| 5890
Dual Element PIR | <ul style="list-style-type: none">• Interchangeable lenses: long range, etc.• Built-in transmitter with battery saver circuit• 40° wide angle pattern• Tamper• Includes two 3 volt lithium batteries (466) |

VOLTAGE TRIGGERS (Connector J7) (Ground Start Module, Keyswitch, Remote Console Sounder)

General Information

Connector J7, located on the right hand side of the main PCB provides 4 trigger outputs for operating the 675 Ground Start Module, the 4146 Keyswitch, a remote console sounding piezo, and for triggering auxiliary alarm signaling equipment (such as the 7720 and 7920SE LORRA Subscriber Radios). Note that these output triggers can be enabled by partition via programming field 2*20.

The pin assignments of this connector are shown below. Use only the 4142TR 9-wire cable (available as an option) for making connections to this connector.

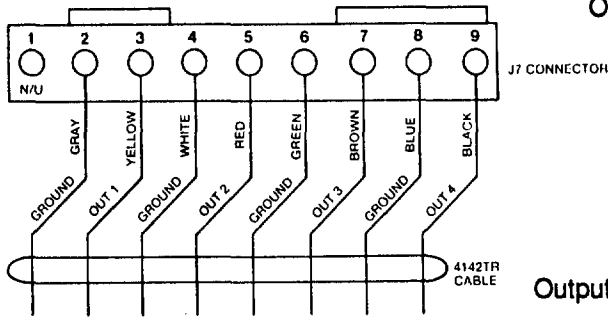

OUT 1: GROUND START OR OPEN/CLOSE
OUT 2: FIRE OR KEYSWITCH ARMED LED
OUT 3: BURGLARY/AUDIBLE PANIC/AUXILIARY
OUT 4: SILENT PANIC/DURESS OR KEYSWITCH READY LED

Output 1 Operates, by default, as a trigger for the 675 ground start module. This output may optionally be programmed to operate as an open/close trigger or as a remote console sounder output. Only one of these options may be used at any time.

Rating: When Activated: 10 - 13.8 VDC through 4K ohms

(2.5mA max)

When De-activated: 100 ohms to ground

Outputs 2 & 4 Operate, by default, as Fire and Silent Panic/Duress triggers respectively. These triggers may optionally be programmed to act as Arm and Ready status indicators when it is desired to use the 4146 keyswitch .

Output 2,3 & 4 Rating: When Activated: 10 - 13.8 VDC through 5K ohms

(2mA max)

When De-activated: 1k ohms to ground

Ground Start Module

An optional 675 Ground Start module can be used for installations having telephone lines which require ground start instead of loop start operation to obtain dial tone from the telco central office.

Not Intended for use in UL Listed applications.

If used, program field 1*46 must be set to "0" (factory default) and the 675 Ground Start Module must be connected to the panel's J7 connector trigger output 1, to auxiliary power, and to the "RING" side of the telephone line as shown in the diagram below.

Use the following procedure to determine which side of the telephone line is the "RING" side:

- Connect the "+" lead of a DC voltmeter to earth ground, and the "-" lead to one side of the telephone line.
- The wire which reads +50VDC is the "RING" side.

When the panel has a message to transmit to the central station, it will seize the line, go off hook, and then trigger the 675 module to connect the "RING" side of the telephone line to earth ground. The panel will cause the module to break the connection between "RING" and earth ground when a dial tone is obtained.

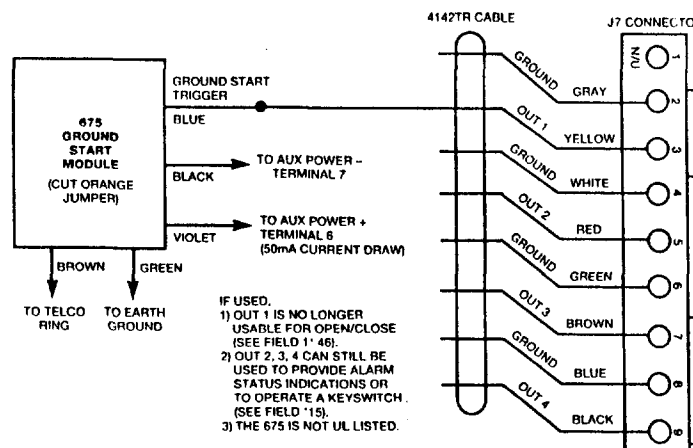

Remote Keyswitch

**NOTE: 4146
Keyswitch is not UL
Listed.**

If the keyswitch option is selected (field *15), the alarm trigger outputs are disabled.

An optional Remote Keyswitch can be used for remote arming and disarming of the system. **Note that keyswitch arming may only be used in one partition.**

If used, program field *15 must be set to the desired partition to enable the keyswitch option, and the 4146 keyswitch's normally open momentary switch and LEDs must be connected to Zone 7 and to the J7 connector trigger outputs respectively. A 2k EOL resistor must be connected across the switch regardless of whether or not zones 2-8 are selected to use EOL resistors. See diagram below.

Note that the system automatically assigns zone type 10 to zone 7 if keyswitch is used.

A momentary short across this zone will arm the system in the "AWAY" mode. If the short is held for more than 3 seconds, the system will arm in the "STAY" mode. (i.e. all zones designated as zone types 4 or 10 will be automatically bypassed). After the system has been armed, the next time zone 7 is shorted, the system will disarm.

An optional closed-circuit tamper switch (model 112) can be wired in series with zone 7, so that, if the switchplate is removed from the wall, the tamper will open, disabling keyswitch operation until the system is next disarmed from the console.

Note: Only one keyswitch with LEDs can be supported by the system's power supply.

Note: Open/close reporting for keyswitch is enabled in field *40, and the keyswitch reports as user 0.

LED Indications are defined as follows:

Green	Red	Meaning
Off	Off	Disarmed & Not Ready
On	Off	Disarmed & Ready
Off	On Steady	Armed Away
Off	Slow Flash	Armed Stay
Off	Rapid Flash	Alarm Memory

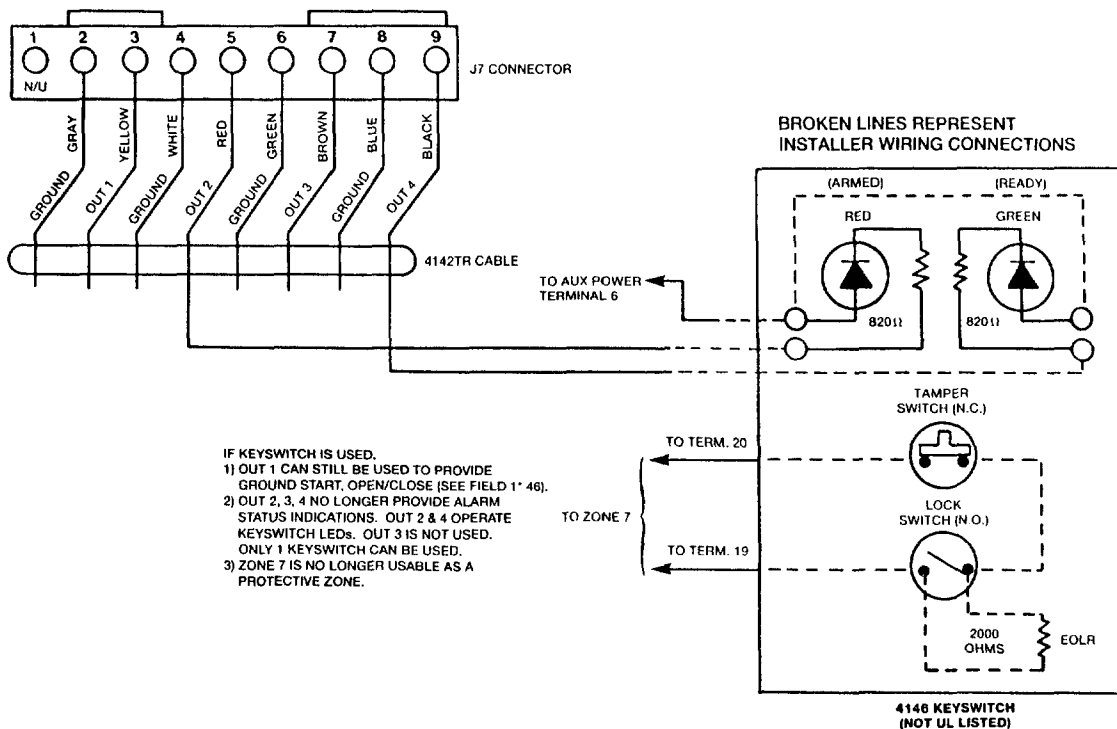

Remote Console Sounder Operation & Wiring

An optional Amseco PAL 328N can be used for installations where it is desired to remote the sounds produced by the console's built-in piezo sounder for one partition. The panel will remote all sounds (i.e. alarm, trouble, chime, entry/exit, etc.) produced by the console's built-in sounder except for the short clicks associated with console key depression. One application of this feature might be to produce chime sounds in a location which is distant from the panel's consoles. This can also be accomplished using relay outputs (see Output Relay section).

If used, program field 1*46 must be set to "2" to enable the remote console sounder option, and the Amseco piezo must be connected between the panel's auxiliary power and the J7 connector trigger output as shown below.

In addition, field *15 must be used to select the partition whose console sounds are to trigger the sounder. Zone 7 must be assigned to be a keyswitch zone (even if keyswitch is not used).

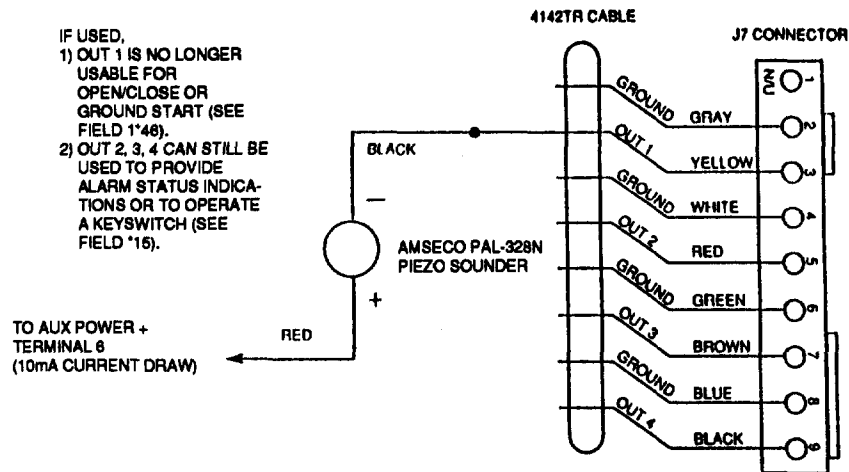

OUTPUT CONTROL (4204 Relay Module/X-10 Devices)

General Information

The 4140XMPT2 supports up to 16 relay outputs. These outputs may consist of relay outputs from the 4204 output relay module (4 relay outputs per module) or X-10 device outputs. Outputs can be activated and deactivated by predetermined events such as turning on lights in the event of an alarm condition and/or closing a fire door in the event of a fire alarm condition. Refer to the PROGRAMMING GUIDE for instructions on programming relay options.

There are many different uses for relays, some of which are shown at the end of this section.

4204 Relay Module

The 4204 Relay Module has 4 form C (normally open and normally closed contacts) relays. Each relay can be used independently for different functions.

The 4204 is wired to the control's console terminals 6-9. Use standard 4-conductor twisted cable (for long wire runs) or the connector supplied with the 4204. Each 4204 should be home run back to the panel. The maximum wire run length from the panel to the 4204 must not exceed:

Wire Gauge	Maximum Length
#22	125 feet
#20	200 feet
#18	300 feet
#16	500 feet

The 4204's DIP switch must be set for a device address and that address must be enabled in the control's Device Programming mode. (Note that some early units have only 4 DIP switches.)

Program the output relays using the control's *93 Menu Mode. Refer to the PROGRAMMING GUIDE for details.

4300 Transformer & X-10 Devices

When using X-10 devices, the 4300 transformer must be used **instead of** the 1361 transformer shown on the Summary of Connections diagram. The 4300 provides AC power to the panel and relays signals from the panel through the premises AC wiring to X-10 devices.

Run a 3-conductor cable between the 4300 interface and the panel. Splice this cable to a 4142TR cable as shown in the diagram below. Note that the white and yellow wires of the 4142TR **must be spliced together**.

X-10 devices plug into standard AC outlets and can be used to perform various functions. Be sure to set the proper house and unit IDs when using X-10 devices.

UL NOTE: X-10 devices and the 4300 are not UL Listed for fire or burglary functions and are intended for home automation.

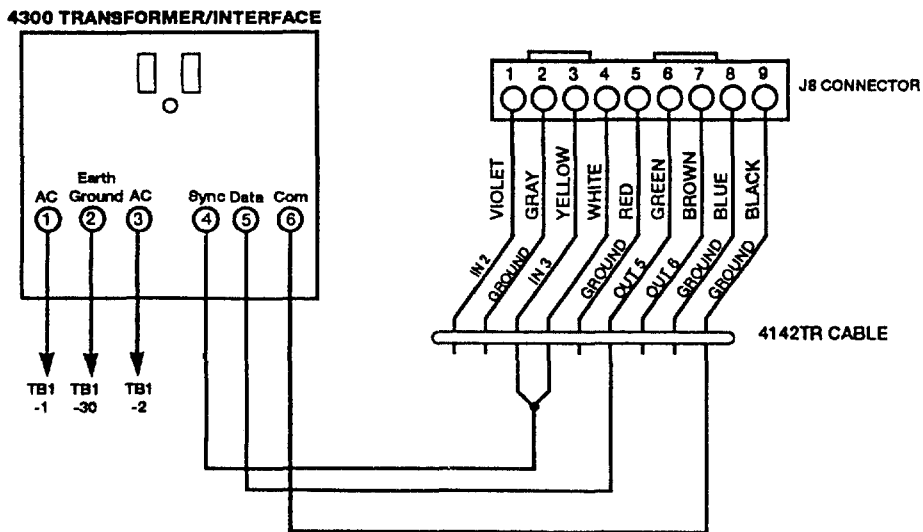

EXAMPLES OF USES FOR RELAYS

The following table lists examples of some possible uses for relays. Refer to the Relay Programming section of the PROGRAMMING GUIDE for detailed information.

LIST OF START AND STOP CHOICES

A = Action 0=No Response; 1=Close for 2 seconds; 2=Close and stay closed; 3=Pulse on and off
EV = Event 0=Not used; 1=Alarm; 2=fault; 3=Trouble; 4=Restore
ZL = ZONE List 1 to 8 (from Field *81) or 0=Not Used. Upon restore of all zones on RESTORE of ZONE LIST, relay action will STOP. It need not be same list as used for START

ZT = Zone Type/System Operation

Choices For Zone Types Are:

00 = No Response	06 = 24 Hr Silent
01 = Entry/Exit	07 = 24 Hr Audible
03 = Perimeter	08 = 24 Hr Aux
04 = Interior Follower	09 = Fire
05 = Trouble Day/Alarm Night	10 = Interior w/Delay

Choices For System Operation:

20 = Arming-Stay	39 = Fire Zone Trouble
21 = Arming-Away	40 = Bypassing
22 = Disarming	41 = AC Power Failure
31 = End of Exit Time	42 = System Battery Low
32 = Start of Entry Time	43 = Communication Failure
33 = Any Burglary Alarm	44 = RF Low Battery
34 = Code + # + 7 + 1	45 = Polling Loop Failure
35 = Code + # + 7 + 2	51 = RF Receiver Failure
36 = At Bell Timeout***	52 = Kissoff
37 = 2 Times Bell Timeout***	54 = Fire Zone Reset
38 = **Chime	58 = Duress

** Should be used to start 2-second close of relay only

***Or at Disarming, Whichever occurs earlier

Additional Stop Choices:

55 = Disarm + 1 Minute
 56 = XX Minutes (Enter XX at 1*74)
 57 = YY Seconds (Enter YY at 1*75)

ACTION DESIRED	A	START				STOP		
		EV	ZL	ZT	P	ZL	ZT	P
TURN ON LIGHTS								
<i>On Entry:</i>								
Close relay at start of entry time and reset with key entry of security code + # + 7+1 *	2	0	0	32	X	0	34	X
Close relay at start of entry time and reset after 1 minute	2	0	0	32	X	0	55	X
Close relay after any burglary alarm and reset with key entry of security code + # + 7 + 2.**	2	0	0	33	X	0	35	X
<i>**Can be used to turn on lights in the event of a burglary alarm...(NOTE: Response types 06, 08, and 09 will not activate relay).</i>								
Turn All Lights off with entry of security code + # + 7 + 2*	2	0	0	00	X	0	35	X
<i>*Can be used to turn off all lights in on a given X-10 House and Unit Id</i>								
Pulse light on trouble condition to attract attention__	3	3	X	00	X	0	22	X
Pulse Light on alarm to attract attention__	3	1	X	00	X	0	22	X
Use a PIR to turn a light on for a pre-set time period*_	2	2	X	00	X	0	56	X

ACTION DESIRED	A	START				STOP		
		EV	ZL	ZT	P	ZL	ZT	P
=You must define a Start zone list (zl) for these applications to work properly. *Can be used to turn on lights in a specific room or area. For example you can automatically turn on the basement light on entry.								
CHIME								
Close relay for 2 seconds during chime. (Chime mode must be turned on at control)	1	0	0	38	X	0	00	X
<i>Chime on Specific zones:</i>								
Zones in zone list (x) close relay for 2 seconds on faults*	1	2	X	00	X	0	00	X
<i>*Will activate relay for any zone type plus panics on 5801 whether control is armed or disarmed. (Console panics will not activate a relay with the configurations above.)</i>								
Zones in zone list (x) close relay for 2 seconds on alarms	1	1	X	00	X	0	00	X
Zones in zone list (x) close relay for 2 seconds on troubles	1	3	X	00	X	0	00	X
BELL OUTPUT								
Zones in zone list (x) close relay on alarms and reset at bell timeout or when disarmed by any either partition.	2	1	X	00	X	0	36	X
Zones in zone list (x) pulse relay on alarms and reset at bell timeout or when disarmed by any partition.	3	1	X	00	X	0	36	X
Close relay after any burglary alarm and reset when disarmed by any partition	2	0	0	33	X	0	22	X
Close relay after any burglary alarm and reset at bell timeout or when disarmed by any partition.	2	0	0	33	X	0	36	X
<i>*Response types 06,08, and 09 will not activate relay. If PULSE relay is desired, enter a 3 in A(action).</i>								
STROBE LIGHT								
Zones in zone list (x) close relay after alarms and reset when disarmed by either partition. (Latching relay for strobes)*	2	1	X	00	X	0	22	X
Zones in zone list (x) pulse a relay after alarms and reset when disarmed by either partition.*	3	1	X	00	X	0	22	X
<i>*Relay will activate for burglary, fire, and panic alarms if programmed into zone list.</i>								
Zones in zone list (x) close relay on alarms and reset with key entry of security code + # + 7 + 1	2	1	X	00	X	0	34	X
SYSTEM STATUS INDICATORS								
Close relay when ARMED-AWAY, reset when DISARMED. (Any partition)*	2	0	0	21	X	0	22	X
Close relay when ARMED-STAY, reset when DISARMED. (Any partition)*	2	0	0	20	X	0	22	X
<i>*If PULSED relay is desired, enter a 3 in A(action).</i>								
Bypassing a zone causes relay to close and will reset with a disarm sequence (code + off.)	2	0	0	40	X	0	22	X
CONFIRMATION OF ARMING DING								
Close relay for 2 seconds at end of exit delay time after system is armed	1	0	0	31	X	0	00	X

ACTION DESIRED	A	START				STOP		
		EV	ZL	ZT	P	ZL	ZT	P
UNLOCK EXIT DOORS								
Close relay on Burg alarm, reset with entry of security code + # + 7 + 1	2	1	X	33	X	X	34	X
Close relay on Fire alarm, reset with entry of security code + # + 7 + 1	2	1	X	09	X	X	34	X
TURN ON EMERGENCY LIGHTING								
An AC loss detection causes relay to close for 2 seconds.*	1	0	0	41	X	0	00	X
<i>*The relay will not reset on restoral of low battery or AC power. For this reason, using "close for 2 seconds" in A(action) is recommended.</i>								
SOUNDING FOR WIRELESS KEYPAD								
Pulse relay at start of entry time and reset when system is disarmed (entry warning)*	3	0	0	32	X	0	22	X
<i>*Relay can be used to turn on an external sounder placed where it can be heard by someone using the wireless keypad.</i>								

Section 3.

REMOTE CONSOLES, SOUNDERS & PHONE CONNECTIONS

REMOTE CONSOLES

General The Control supplies up to 750 mA of auxiliary power for remote consoles, polling loop devices and/or other auxiliary devices such as motion detectors or 4-wire smoke detectors*.

The Controls support, independent of auxiliary power considerations, up to 16 addressable remote consoles (4137AD, 5137AD, 6139).

Up to twelve (12) 4137AD or eight (8) 5137AD or seven (7) 6139 consoles can be powered from the auxiliary power output provided that the total current drawn from this output does not exceed 750 mA. Keep this in mind when adding remote consoles so you don't overdraw current from the panel. This would result in a battery which does not charge properly or possibly a tripped auxiliary solid state circuit breaker.

If the auxiliary load is determined to be greater than 750 mA, then additional consoles can be powered from a separate power supply. Refer to the POWERING ADDITIONAL CONSOLES paragraph for a diagram that shows how to make connections to the separate power supply.

* 4-wire smoke detectors cannot be used in UL Listed applications.

4137AD Addressable Fixed-Word Console

Equipped with a liquid crystal display (LCD) using 2-digit numerics for zone identification, and a set of pre-designated English language prompts, such as "READY", "NOT READY", etc. for system status. Keys are backlit. A built-in alarm sounder is also included, eliminating the need for a separate indoor sounder. DIP switch selectable ID number, which allows console to display status of the partition to which it is assigned. 60mA current draw.

5137AD Addressable Alpha Console

Equipped with a programmable 2-line, 32-character (16 characters per line), backlit alphanumeric LCD for complete zone identification in English language (if descriptors are programmed). Keys are also backlit.

An alarm sounder is built in, eliminating the need for a separate indoor sounder.

DIP switch selectable ID number, which allows console to display status of the partition to which it is assigned.

90mA current draw.

6139 Deluxe Addressable Alpha Console

The 6139 Remote Consoles are keypad addressable (no DIP switches) console, and features a red "ARMED" LED which lights when the system is armed, and a green "READY" LED* which lights when the system is ready to be armed (no zone faults present). This console also features display backlighting. The keypad on this console is located behind a decorative door, and is continuously backlit for ease in use. The keypad also features special panic keys, labeled A, B, & C (the D key is not used), which are the equivalent to the panic pairs of keys 1/Q, Q/#, & 3/# respectively. Note that these keys must be held down for at least 2 seconds to activate an alarm.

* Note that the function of this LED (system ready) differs from the function of the green LED on Ademco's 4137AD & 5137AD consoles.

The console can be surface mounted directly to a drywall, or to a single or double gang electrical box. For flush mounting to drywall, use the optional 6139TRK flush mount kit.

100mA current draw.

Programming The Consoles

The consoles can be set for an address of 0-30

IMPORTANT! You must select an address of 0, 1, 2, or 3 if standard defaults are to be programmed, since these are the only console addresses enabled by the standard default. Refer to the addressable console DIP switch table at the end of this manual to set the 4137AD and 5137AD address ID number. Refer to the instructions provided with the 6139 to set its ID number.

Do not use address 31 with the 4140XMPT2. Address 31 causes the console to operate in non-addressable mode (i.e. works like a standard, non-addressable console).

Consoles must also be programmed for type, partition number and console sounder suppression options. Refer to the PROGRAMMING GUIDE (#93 MENU MODE-DEVICE PROGRAMMING) for instructions.

Mounting The Consoles

Note that field wiring to the consoles must be completed before the consoles can be mounted.

The consoles can be either surface mounted or flush mounted (using an appropriate Trim Ring Kit: 5137TRK or 6139TRK). Refer to the mounting instructions and template included with the console and/or trim ring kit for specific information.

Be sure to take the height of the users into account when mounting consoles.

Wiring Consoles

Consoles may be wired to a single wire run or individual consoles may be connected to separate wire runs. The maximum wire run length from the panel to a console which is homerun back to the panel must not exceed:

Wire Gauge	Maximum Length
#22 gauge	450 feet
#20 gauge	700 feet
#18 gauge	1100 feet
#16 gauge	1750 feet

NOTE: The length of all wire runs combined must not exceed 2000 feet when unshielded quad conductor cable is used (1000 feet if shielded cable is used.) If more than one console is wired to a run, then the above maximum lengths must be divided by the number of consoles on the run (i.e. the maximum length would be 225 feet if two consoles are wired on a #22 gauge run).

Powering Additional Consoles

Up to twelve 4137AD or eight (8) 5137AD or seven (7) 6139 consoles can be powered from the auxiliary power output provided that the 750mA rating is not exceeded. The backup battery will supply power to these consoles in the event that AC power is lost.

Additional consoles can be connected to the system by using a regulated, 12VDC power supply (eg. 487-12 supplies 12V, 250mA; 488-12 supplies 12V, 500mA). Use a UL Listed, battery backed supply for UL installations. Note that the maximum number of consoles supported by the system is 16.

Connect additional consoles as shown below, using the console wire colors shown. Make sure to observe the current ratings for the power supply used.

Wire run lengths from the 4140XMPT2 to consoles are listed in the WIRING CONSOLES paragraph (maximum combined wire run lengths for all consoles must not exceed 2000', or 1000' if shielded cable is used).

IMPORTANT: Make connections directly to the screw terminals as shown. Make no connection to the console blue wire.

The 487-12/488-12 power supplies have a backup battery which can power these consoles in the event of AC power loss. Note that consoles powered from supplies which do not have a backup battery will not function when AC power is lost. In this case, make sure to power at least one console from the Control's auxiliary power output.

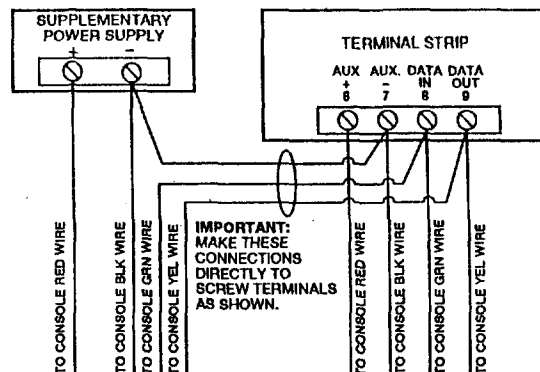

EXTERNAL SOUNDERS

Relay Output

The Control provides a wet bell relay output which is used to power external alarm sounders. Connections are made to terminals 4 (positive output) and 5 (negative return). See SUMMARY OF CONNECTIONS Diagram.

UL Household Installations

For installations which must provide UL Listed protection, the total current drawn from this output and the auxiliary power output, combined, must not exceed 750mA in order to comply with the battery independence requirements. If two System Sensor PA400 piezo alarm sounders, wired in parallel, are used (24mA total), then (750mA – 24mA=) 726mA is available for auxiliary output use.

Non-UL Installations

For non-UL installations, the total current drawn from this output can be up to 2.8 amps. A battery must be installed since current in excess of 750mA is supplied by the battery. Up to two 702 sirens can be used, wired in series. Up to two 719 sirens can be used wired in parallel.

IMPORTANT: Going beyond the above mentioned limits will overload the power supply or may possibly trip the bell output circuit protector.

Compatible Sounders

702
Outdoor Siren (not UL Listed)

- Self-contained siren (driver built-in) and weatherproof for outdoor use. Can be wired for either a steady or yelp sound and is rated at 120 dB @ 10 feet. This siren can also be tamper protected, or can be mounted in a metal cabinet (716), which can be tamper protected.

719
Compact Outdoor Siren (not UL Listed)

- Compact, self-contained siren (driver built-in), and weatherproof for outdoor use. Can be wired for either a steady or yelp sound, and is rated at 90 dB @ 10 feet. A 708BE cabinet is available, which can be tamper protected if necessary.

740
High Intensity Sounder

- Compact high intensity sounder rated at 123 dB @ 10 feet. This sounder emits an 'ear piercing', high frequency sound. This sounder can be mounted indoors (bracket included) or outdoors (in 708BE cabinet).

747
Indoor Siren

- Attractive, self-contained indoor siren (driver built-in), provides steady or warble tones and is rated at 95dB @ 10 feet.

ABB1031
Motor Bell & Box

- AMSECO motor bell & box, rated at 81 dB @ 10 feet.

PA400B
(beige)/PA400R (red)
Indoor Piezo Sounder

- System Sensor indoor piezo sounder (red or beige), rated at 90 dB @ 10 feet.

UL NOTE: Use only UL Listed sounding devices for UL installations.

PHONE CONNECTIONS

Phone Line Connections

Incoming phone line and handset wiring is connected to the main terminal block as follows (refer to SUMMARY OF CONNECTIONS Diagram):

- TB1-26: Local Handset (TIP)
- TB1-27: Local Handset (RING)
- TB1-28: Incoming Phone Line (TIP)
- TB1-29: Incoming Phone Line (RING)

If it is desired to connect the panel to phone lines that require ground start capability, then a 675 Ground Start Module must be used. This module is triggered by one of the outputs on the connector labeled J7 (see VOLTAGE TRIGGERS section).

Warning

To prevent the risk of shock, disconnect phone lines at telco jack before servicing the panel.

PABX

If the communicator is connected to a telephone line inside a PABX, be sure the PABX has a back-up power supply that can support the PABX for 24 hours. Many PABXs are not power backed up and connection to such a PABX will result in a communication failure if power is lost.

Section 4.

MOUNTING THE CONTROL, PC BOARD & LOCK

General The 4140XMPT2 is supplied with a 12.5"W x 14.5"H x 3"D cabinet suitable for use in residential and non-certified commercial burglary installations.

Mount the Control cabinet to a sturdy wall using fasteners or anchors (not supplied) in a clean, dry area which is not readily accessible to the general public. The back of the Control cabinet has 4 holes for this purpose.

Follow the instructions below for mounting the 4140XMPT2 PC board into the cabinet and for mounting the Control's lock to its cabinet door.

Mounting The 4140XMPT2 PC Board

Before mounting the circuit board, be certain that the appropriate metal knockouts have been removed. **DO NOT ATTEMPT TO REMOVE THE KNOCKOUTS AFTER THE CIRCUIT BOARD HAS BEEN INSTALLED.**

1. Hang the three mounting clips on the raised cabinet tabs. Observe proper clip orientation to avoid damage to the clip when mounting screws are tightened and to avoid problems with insertion and removal of the PC board.
2. Insert the top of the circuit board into the slots at the top of the cabinet. Make certain that the board rests in the slots as indicated in step 2 detail.
3. Swing the base of the board into the mounting clips and secure the board to the cabinet with the accompanying screws (as illustrated in step 3 detail).

Advisory

Make certain that the mounting screws are reasonably tight to insure that there is a good ground connection between the PC board and the cabinet. Also, dress field wiring away from the microprocessor (center) section of the PC board. The cabinet provides 2 loops on its left and right sidewalls for anchoring field wiring using tie wraps. These steps are important to minimizing the risk of panel RF interference with television reception.

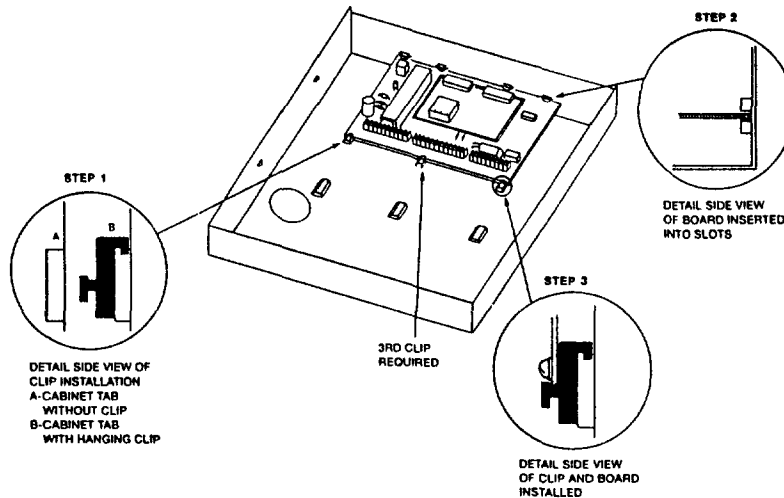

Mounting The Cabinet Lock

1. Remove the lock knockout on the control cabinet cover. Insert the key into the lock. Position the lock in the hole making certain that the latch will make contact with the latch bracket when the door is closed.
2. While holding the lock steady, insert the retainer clip into the retainer slots.

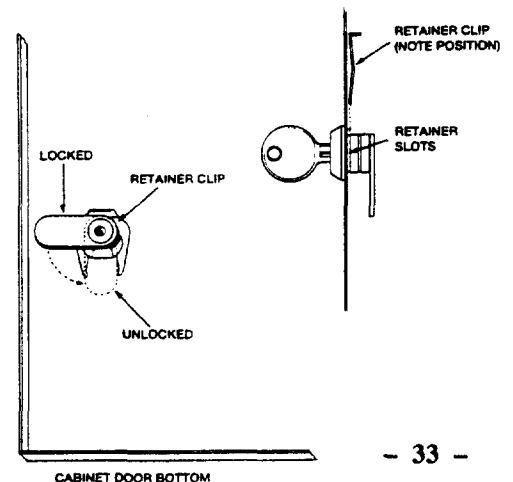

Section 5.

POWERING THE SYSTEM & SETTING THE REAL-TIME CLOCK

POWERING THE SYSTEM

Primary Power Power to the Control panel is supplied by model No. 1361* Plug-in Transformer which is rated at 16.5VAC, 40VA. Caution must be taken when wiring this transformer to the panel to guard against blowing the fuse inside the transformer (non-replaceable).

* NOTE: Use 1361CN Transformer in Canadian installations.

Back-Up Power In the event of an AC power loss, the Control panel is supported by a back-up, rechargeable gel cell battery. YUASA NP4-12 (12V, 4AH) and NP7-12 (12V, 7AH) batteries are recommended. **Do not use Gates batteries (sealed lead-acid type).**

The standby battery is automatically tested every 24 hours, beginning 24 hours after exiting programming mode. In addition, entry into the test mode will cause a battery test to be initiated.

BATTERY STANDBY TABLE

AUX. STANDBY CURRENT DRAW				
AMP-HRS.	200mA	400mA	600mA	750mA
4.0	6 hrs.	4 hrs.	3 hrs.	2.5 hrs.
6.0-7.0	11 hrs.	7 hrs.	5.5 hrs.	4 hrs.

NOTE: These figures are approximate, and may vary depending upon the age, quality, and capacity of the battery at the time of the AC loss.

Earth Ground Connections

In order for the lightning transient protective devices in this product to be effective, the designated earth ground terminal, must be terminated in a good earth ground. The following are examples of good earth grounds available at most installations:

Metal Cold Water Pipe: Use a non-corrosive metal strap (copper is recommended) firmly secured to the pipe to which the ground lead is electrically connected and secured.

AC Power Outlet Ground: Available from 3-prong, 120VAC, power outlets only. To test the integrity of the ground terminal, use a three-wire circuit tester with neon lamp indicators, such as the UL-Listed Ideal Model 61-035, or equivalent, available at most electrical supply stores.

Power-Up Procedure

1. Fill out the Polling Loop Current Draw and Auxiliary Device Current Draw Worksheets shown below. Make sure that the currents drawn from these outputs do not exceed their respective ratings.
CAUTION: Failure to observe the polling loop current rating will cause polling loop malfunction. Failure to observe the auxiliary output current rating will result in a battery which does not charge properly or possibly a tripped circuit breaker.
2. Wire the 1361 transformer (1361CN in Canada) to the panel (before connecting the battery) as shown in the SUMMARY OF CONNECTIONS diagram. Do not plug in at this time.
3. Connect all polling loop and auxiliary devices, such as consoles, PIRs, etc.
4. Plug the 1361 into an 24 hour, uninterrupted AC outlet. After a few seconds, the green POWER LED on the console(s) should light and the console(s) should display "DISARMED READY TO ARM."
5. Connect the battery as shown in the SUMMARY OF CONNECTIONS diagram.

POLLING LOOP CURRENT DRAW WORKSHEET

RPM DEVICE	CURRENT	# UNITS	TOTAL CURRENT
4194 Contact	1 mA		
4192SD Photo Smoke	0.4 mA		
4192SDT Smoke w/Heat	0.4 mA		
4192CP Ion Smoke	0.4 mA		
4275 Dual PIR	1 mA		
4278 Quad PIR	1 mA		
4190 2-Zone RPM	1 mA (LOW) 2 mA (HIGH)		
4208 8-Zone RPM	16 mA		
4280 63 Zone RF	40 mA		
4280-8 8 Zone RF	40 mA		
	TOTAL **		

** If the total current draw exceeds 64 mA, a 4197 Loop Extender module must be used.

** If using two 4280s or 4280-8s, you can power one of them from auxiliary power instead of using a 4197 loop extender module.

AUXILIARY DEVICE CURRENT DRAW WORKSHEET

DEVICE	CURRENT	# UNITS	TOTAL CURRENT
4137AD Console	60mA		
5137AD Console	90 mA		
6139 Console	100mA		
675 Ground Start Module	50 mA		
4280 or 4280-8 Receiver	40 mA		
Built-in Polling Loop	(total poll loop worksh)		
4281 RF Receiver	35mA		
5881 RF Receiver	50mA		
4197 Poll Loop Extender	80 mA		
*			
*			
*			
		TOTAL (750mA max)	

* If using hard-wire devices such as PIRs, refer to the specifications for that particular unit's current draw.

_ Only applies if powered from Control's auxiliary power.

SETTING THE REAL-TIME CLOCK

PROCEDURE

Important:
This method is different from the previous method of setting the clock.

NOTE: A 5137AD or 6139 alpha console must be used to set the real-time clock, or the clock can be set via the Downloader software. Only users with installer or master authority level can set the real-time clock.

To enter real-time clock mode, enter installer or master code + #63. A typical display will show:

```
TIME/DATE - THU
12:01 AM 01/01/90
```

The day of the week is automatically calculated based on the date entered. Time and date entries are made by simply entering the appropriate hour, minute, month, day and year. Pressing the [*] key accepts the entered value and moves the cursor to the right. Pressing the [#] key moves the cursor to the left of the display, to the previous position.

To set the time and date, simply enter the correct hour then press [*] to move to the minutes and make the correct entry.

Press [*] again, then toggle the AM/PM by pressing any key 0-9.

Press [*] to move cursor to the month position and enter the correct month using a 2-digit entry.

Press [*] and enter the correct date.

Press [*] and enter the correct year.

To exit clock mode, press the [*] key after the cursor is in the year position.

Section 6. SYSTEM OPERATION

SECURITY ACCESS CODES

General Information

The System allows up to 128 security access codes to be assigned (maximum 99 per partition), each identified by a user ID number. In addition, the Quick Arm feature can also be programmed, which enables the [#] key to be pressed instead of entering the security code when arming the system. The code must still be entered when disarming the system.

Note that Open/Close reporting of Quick Arm is enabled if User 2 is enabled for Open/Close reporting, and that Quick Arm reports as User 0.

User Codes & Levels Of Authority

Each user of the system can be assigned various levels of authority (tells system what system functions that user is authorized to do), and can have different levels of authority within each partition. Use the "View Capabilities" keypad function to view the partitions and authority levels for which a particular user is authorized. In highest to lowest ranking, these levels are described below.

Level	Title
0	Installer
1	Master
2	Manager
3	Operator level A
4	Operator level B
5	Operator level C
6	Duress

Installer (Level 0) User 1	<ul style="list-style-type: none"> • Programmed in field *00 (default=4-1-4-0). Can be changed by installer. • Can perform all system functions (arm, disarm, bypass, etc.) and is the only user that can enter program mode. • Only code that allows entry to program mode. • Installer code lockout if exit program mode via *98. This prevents installer from reaccessing program mode. The only way to access Programming mode once this feature is activated, is by powering down the system and powering up again, and then pressing both the * and # keys at the same time within 30 seconds of power up. • The installer must program at least one master code. Master codes are the codes intended for use by the primary users of the system. • Can add, delete, or change master, manager, or operator codes. • Can select open/close reports for any user. • Can perform normal system functions, but cannot disarm if armed by a code other than Installer's code (including Quick Arm). • Enable open/close reporting for installer in field *39.
Master (Level 1)	<ul style="list-style-type: none"> • The Master Code is the code intended for use by the primary users of the system when performing system functions, and can be changed by the Master User. • The master codes can be used to assign up to 99 lower level codes, which can be used by other users of the system who don't have a need to know the master code. • As shipped from the factory, there are no master or manager codes pre-programmed. The installer must program at least one master code during initial installation. • Master cannot assign anybody a level of 0 or 1. • Can change his own code. • Can add, delete, change manager or operator codes. Each user's code can be individually eliminated or changed at any time. • Open/close reporting of added users are same as that of the master or manager adding the new user. • Can perform all system functions.

User Codes & Levels Of Authority (cont.)

<p>Manager (Level 2)</p>	<ul style="list-style-type: none"> • Can perform all system functions (Arm, Disarm, Bypass, etc.) programmed by Master. • May create other users of the system below this level (Manager cannot assign anybody a level of 0, 1, or 2). • May change his own code. • May add, delete, change operators. • Open/close reporting of added users will be same as his own (enabled or disabled as assigned by installer or master). • May operate a partition. 												
<p>Operator (Levels 3-5)</p>	<ul style="list-style-type: none"> • Operators can arm and disarm the system to the authority assigned, but cannot add or modify any user code. • May operate a partition with one of the three OPERATOR authority levels A through C listed below. <table border="1" data-bbox="786 562 1364 697"> <thead> <tr> <th>Level</th> <th>Title</th> <th>Functions Permitted</th> </tr> </thead> <tbody> <tr> <td>3</td> <td>Operator A</td> <td>Arm, Disarm, Bypass</td> </tr> <tr> <td>4</td> <td>Operator B</td> <td>Arm, Disarm</td> </tr> <tr> <td>5</td> <td>Operator C</td> <td>Arm, Disarm only if armed with same code</td> </tr> </tbody> </table> <ul style="list-style-type: none"> • Operator C (sometimes known as Baby-sitter code), cannot disarm the system unless the system was armed with that code. This code is usually assigned to persons who may have the need to arm and disarm the system at specific times only (ex. a baby-sitter needs to control the system only when baby-sitting). 	Level	Title	Functions Permitted	3	Operator A	Arm, Disarm, Bypass	4	Operator B	Arm, Disarm	5	Operator C	Arm, Disarm only if armed with same code
Level	Title	Functions Permitted											
3	Operator A	Arm, Disarm, Bypass											
4	Operator B	Arm, Disarm											
5	Operator C	Arm, Disarm only if armed with same code											
<p>Duress (Level 6)</p>	<ul style="list-style-type: none"> • The duress code is a means of sending a silent alarm to a central monitoring station if the user is being forced to disarm (or arm) the system under threat. This feature is only useful if the system is connected to a central station. • When the system's Auxiliary Voltage Triggers are connected to another communication's media (Derived Channel/Long Range Radio), note that duress is signaled on the same trigger that signals silent panic (whereas duress has its own unique report when digitally communicated). • The duress code is assigned on a partition by partition basis and can be any code desired. • When used, the system will disarm (or arm), but will also send a silent alarm to the central station (if service is connected). There will be no indication at the console that an alarm was sent.. • Duress Reporting Note: The Duress report triggering logic activates on the 5th key depression (such as OFF), not the 4th key depression (last digit of code). Duress reports will not be triggered if the 5th key is a [*], such as when performing a GOTO or viewing the capabilities of a user. 												

Open/Close Reporting Note: When adding a user, the system will only prompt for Open/Close report capability if the user is being added by the Installer. When a Master or Manager adds a new user, the new user's Open/Close reporting enable will be the same as that of the Master or Manager adding the user. If Open/Close reports are required to be selectable by the Master or Manager, the Installer should assign two Master or Manager user codes: one with Open/Close reporting enabled, and one without Open/Close reporting.

General Rules on Authority Levels and changes

The following rules apply to users when making modifications within the system based on the user code authority levels:

- Master Codes and all lower level codes can be used interchangeably when performing system functions within a partition (a system armed with a user's temporary code can be disarmed with the Master Code or another user's temporary code), except the Operator Level C Code described above.
- A user may not delete or change the user code of the SAME or HIGHER authority than which he is assigned.
- A user (levels 0, 1 & 2 only) may only ADD users to a LOWER authority level.
- A user may assign other users access to only those partitions to which he himself has access.
- A user can only be DELETED or CHANGED from within the partition he is assigned.
- User numbers must be entered as 2-digit entries. Single digit user numbers must, therefore, always be preceded by a "0" (example, 03, 04, 05, etc.). Make sure the end user understands this requirement. Temporary codes are entered as 4-digit numbers.

Important!: Unless Ademco Contact ID reporting is used, only user codes #1 - #15 can uniquely report to the central station using the communication formats provided. Users #16 - #99 will report as User #15, if enabled for open/close reporting, for the other reporting formats.

Multiple Partition Access Examples (GOTO Function)

To make a partitioned environment particularly useful, the system must allow for certain people to have access to other partitions. This is particularly true in the Factory/Office environment where the president of the company wants access to any area of his company. The 4140XMPT2 has total flexibility in supporting this requirement. On a USER basis, each user is programmed for a base partition (the one he normally is assigned) and one or more partitions which he can be authorized to access.

In addition, within each partition, each USER may be programmed to have different levels of authority. For example, User #3, the V.P. of Engineering, could be assigned to work within the Engineering Department (Partition 1) of ABC Manufacturing. Since he needs the full capabilities in his area, he is assigned as a MASTER with Level 1 authority. This means he may Arm, Disarm, Bypass, Add or Modify users in partition 1. It is also a requirement that he be able to gain access to the manufacturing area (partition 2) on an emergency basis. You can set this up easily with the 4140XMPT2 by now requesting that he also be assigned to partition 2, with a level of authority set lower, such as Level 4 (OPERATOR Level B) which allows him to Arm and Disarm, but nothing else. The control will automatically assign him the next available user number within partition 2 and does not require reprogramming of his already existing 4 digit security code! This type of setup can be done for each user of the system and for any combination of up to 8 partitions!

EXAMPLE OF MULTIPLE PARTITION ACCESS

Part 1	Part 2	Part 3	Part 4	Part 5	Part 6	Part 7	Part 8
User 3	User 5						
Level 1	Level 4						
Master	Oper B						

In the above example, User 3 has MASTER authority in partition 1 and OPERATOR B authority in partition 2. His user number in partition 2 is User 5 and his 4 digit code is the same for both partitions. Note that if a user number is already being used in a partition, the system will automatically assign an unused User number.

Assigning users to other partitions is one thing, but how about actually being a user and trying to "see" one of the other partitions? The 4140XMPT2 has developed a simple key sequence (code + [*] + partition number 0-8, partition 0 returns to the default partition for that console) scheme for a user to go to another partition.

Once there, the current display becomes attached to that partition and status requests, etc. are now displayed for that partition, unless a period of 120 seconds elapses with no key entries. To return to your original partition, you may enter the same key sequence and end it with your normal partition number or "0". You're now back to where you started. It's that simple! You may view this operation as a big selector switch and you are at the switch at the console.

EXAMPLE: User may be regularly assigned to partition 1. This would be the default display for this user, however he may "select" to go to partition 2 for example. (Assumes he has been programmed for access to partition 2) The user enters his normal access code and the proper sequence to select another partition followed by the number 2 for partition 2. The display will now select partition 2 information for view and further action. In the above example notice that no access is allowed for this user into partitions 3 - 8. Attempts to access these partitions would be denied automatically.

To ADD a Master, Manager or Operator code

Installer must program at least one Master code.

- Or Master or Manager code, but must be code with higher level of authority than the code being changed. (i.e. Master code can add a Manager or Operator level code, but cannot add another Master code; a Manager code can add an Operator level code, but cannot add a Master or another Manager code).

Important!: During user code entry, normal key depressions at other consoles in a partition will be ignored. However, panic key depression will cause an alarm and terminate user entry.

Enter Installer Code- + [8] + new User # (00-99) + new User's code
Console will prompt for the Authority Level for this user.

User Number = 03
Enter Auth.Level

Enter the level number as follows:

- 1 = Master (Arm, Disarm, Bypass, add or modify lower level users)
- 2 = Manager (Arm, Disarm, Bypass, add or modify lower level users)
- 3 = Operator Level A (Arm, Disarm, Bypass)
- 4 = Operator Level B (Arm, Disarm)
- 5 = Operator Level C (Arm, Disarm only if system armed with this code)
- 6 = Duress (Arm, Disarm, triggers silent panic alarm)

Console will then prompt for Open/Close reporting option for this user.

Open/Close Rep.?
0 = NO , 1 = YES

Press 0 (NO) or 1 (YES), depending on whether or not arming/disarming by this user will trigger opening & closing reports.

Access Group?
Enter 0-8

If access schedules have been programmed, this prompt appears. Enter the user's access group number (1-8) if this user should have limited access to the system. Enter 0 if no access group should be assigned.

RF Button ?
0=NO , 1=YES

If a 5800 series button transmitter has been enabled, and not assigned to a user, this prompt will appear.

Enter Button ZN #
(01-87)

If yes was given as the answer to the RF button question, the zone number for the button will be requested. Enter one of the zone numbers assigned to the button transmitter as AWAY, STAY or DISARM. The system will then assign any STAY, AWAY or DISARM buttons of the transmitter to this user number..

Multi-Access ?
0 = NO , 1 = YES

Press 0 (NO) or 1 (YES). If NO, the program exits this mode. If yes, the Console prompts for the Global Arm option for this user.

Global Arm ?
0 = NO , 1 = YES

Press 0 (NO) or 1 (YES), depending on whether or not this user will be allowed to arm more than one partition via Global Arm prompts (described in the KEYPAD FUNCTIONS section) .

If the Multi-Access option was selected for this user, the console now prompts for the user's access to the next partition.

Part. 2 – SHOP ?
0 = NO , 1 = YES

Press 0 (NO) or 1 (YES), depending on whether or not this user will have access to the displayed partition number. If NO, the console displays this prompt for the next partition number in sequence.

If YES, the console prompts for the following:

- User's authority level in the displayed partition (see Authority Level prompt above). Note that the user number in the displayed partition is automatically assigned.
- Open/Close option for this user in the displayed partition (see Open/Close prompt above).
- Global Arm option for this user in the displayed partition.

When all partitions have been displayed, the console will scroll through all partitions to which access has been assigned, and will display the user number, authority level, open/close and global arm options that were programmed for each partition the user was granted access. For example:

Part. 1 S WHSE
User 03 Auth=3G.

Note that the "G" following the authority level indicates that the global arm feature is enabled for this user in the displayed partition, and that the period at the end of the second line indicates open/close reporting is enabled for this user in the displayed partition. The "S" indicates the partition from which the user may be changed or deleted.

**To CHANGE a Master,
Manager or Operator
code**

Enter Installer code* + [8] + User number (00-99) + new code for that user.

The system will detect that the user number is already assigned and will prompt if this is a new user. Press 0 (NO).

The system will then confirm that the change is allowed based on authorization level. If the user number is the same as the Installer's, the system will prompt for the new code to be reentered. This prevents accidentally changing a high level code.

* Or Master or Manager code, but must be code with higher level of authority than the code being changed. (i.e. Master code can change a Manager or Operator level code, but cannot change another Master code; a Manager code can change an Operator level code, but cannot change a Master or another Manager code).

Enter Installer code* + [8] + User number (00-99) + Installer code

The system will prompt if this code should be deleted. Press 0 (NO) or 1 (YES).

If yes, that user's code will be removed from all partitions to which it had been assigned, and all authorization levels and other information about that user will be deleted. Note that a user can only be deleted from the partition in which it was first assigned, and can only be deleted by a user with a higher authority level. A user cannot delete himself.

* Or Master or Manager code, but must be code with higher level of authority than the code being deleted. (i.e. Master code can delete a Manager or Operator level code, but cannot delete another Master code; a Manager code can delete an Operator level code, but cannot delete a Master or another Manager code).

**To EXIT The User Code
Entry Mode**

Press either [Q] or [#], or don't press any key for 10 seconds.

KEYPAD FUNCTIONS

General Information

Note that user related scheduling functions and programming is described in the Programming guide (setting temporary schedules, programming timed events, etc.)

The keypad allows the user to arm and disarm the system, and perform other system functions, such as bypassing zones, view messages from the central station and display zone descriptors. Zone and system conditions (alarm, trouble, bypass) are displayed in the Display Window.

When an alarm occurs, console sounding and external sounding will occur, and the zone(s) in alarm will be displayed on the console. Pressing any key will silence the console sounder for 10 seconds. Disarming the system will silence both console and external sounders. When the system is disarmed, any zones that were in an alarm condition during the armed period will be displayed (memory of alarm). To clear this display, simply repeat the disarm sequence (enter the security code and press the OFF key).

The consoles also feature chime annunciation, and 3 panic key pairs (for silent, audible, fire or personal emergency alarms) which can notify the central station of an alarm condition, if that service is connected.

Arming Functions

Note that if QUICK ARM is enabled (field *29), the [#] key can be pressed instead of entering the security code, for any of the arming procedures (Away, Stay, Instant, Maximum, etc.).

The following is a brief list of system commands. For detailed information concerning system functions, refer to the User's Manual.

Disarmed Not Ready Before arming, the system must be in the READY condition (all zones must be intact). If the "NOT READY" message appears, press the READY [*] key to display faulted zones.

Arming Away Enter code + AWAY [2].

Arming Stay Enter code + STAY [3].

Arming Instant Enter code + INSTANT [7].

Arming Maximum Enter code + MAXIMUM [4].

Global Arming If enabled for the user, the console will display the following:

ARM ALL ?
0 = NO, 1 = YES

If NO, the console prompts for arming each partition individually. If YES, the system attempts to arm all partitions allowed by this user. If there are any faults (open doors, windows, etc.) the console will display them. See notes below. These faults must be corrected or the zone bypassed before arming will occur. When faults are corrected, repeat the arming procedure.

Global Arming Notes:

1. When using the Global Arm feature, if there are faults in any of the selected partitions, the system will enter a summary mode in which the faulted zones of all of the selected partitions will be displayed. These faults must be corrected or bypassed (code + BYPASS + [#] will attempt to bypass the faults in all of the selected partitions). This summary mode will end in approx. 120 seconds if no keys are pressed.
2. If, when disarming the system using a Global Disarm, any of the selected partitions has a condition which would cause the console to beep (such as alarm memory or a trouble condition), the system will cause the console to beep and will enter a summary mode in which the alarm memory or trouble conditions of all of the selected partitions will be displayed. This mode will continue until either approx. 120 seconds elapses or a second disarm occurs which clears the beeping condition.
3. Global arming cannot be performed from a wireless keypad or a non-alpha display console.

**Disarming
Bypassing Zones**

Enter code + OFF [1].

Enter code + BYPASS [6] + zone number. To automatically bypass all faulted zones, use "Quick Bypass" method: Enter code + BYPASS + [#].

Chime Mode

Enter code + CHIME [9]. To turn chime mode off, enter code + CHIME again.

SUMMARY OF ARMING MODES

Mode	Features For Each Arming Mode			
	Exit Delay	Entry Delay	Perimeter Armed	Interior Armed
AWAY	Yes	Yes	Yes	Yes
STAY	Yes	Yes	Yes	No
INSTANT	Yes	No	Yes	No
MAXIMUM	Yes	No	Yes	Yes

Access Control

If programmed, one relay may be used for access control. To activate this relay, the user enters his user code + [0]. The relay will pulse for 2 seconds.

Delay Closing Time

If open/close schedules are used, end users can manually extend the closing window by up to 2 hours. This is useful if a user must stay on the premises later than usual. User must have authority level of manager or higher.

To extend the closing window, enter user code + # +82. The following will be displayed.

Closing Delay ? Hit 0-2 Hours

Enter the number hours, 1 or 2, by which the end of the closing window should be delayed. Note that the delay is from the scheduled closing time, not from the current time. Press * to accept entry and exit this mode. Press # to exit this mode without changes.

The system will send a "Schedule Changed" message to the central station when the closing window is delayed.

Important: The delay cannot be reduced once it is set. It can only be increased. This is to prevent the user from deleting the delay after the normal window expires, thereby missing the end of the window.

Partition "Goto" Commands

Each console is assigned a default partition for display purposes, and will show only that partition's information. To see information for another partition, or perform system functions in another partition, use the GOTO command (code + [*] +partition number 0-8). The console will remain in the new partition until directed to go to another partition, or until 120 seconds has elapsed with no keypad activity.

View Capabilities Of A User

The console will display the partitions that user is authorized for, the user number, and the authority level for all partitions authorized. Enter code + [*] + [*]. The user's capabilities in each authorized partition will typically be displayed as follows:

Part. 1 WHSE User 01 Auth.=1.

The user's Open/Close report capability is shown by the dot following the authority level. If Open/Close is not enabled for a user, the dot will not appear.

Viewing Downloaded Messages

Users may occasionally receive messages on the console display from their installation company. When this occurs, the console will display "Message. Press 0 for 5 secs.". Instruct the user to press and hold the 0 key to display the central station's message. Note that the system must be in the READY state to view these messages.

Using The Built-In User's Manual

An abbreviated User's Manual is stored in the system's memory, and can be particularly useful to the end user if the printed User's Manual is not conveniently accessible when the user needs to perform a seldom used and unfamiliar system procedure. The Built-in User's Guide is displayed by simply pressing any of the function keys (e.g., OFF, AWAY, STAY, MAXIMUM, BYPASS, INSTANT, CODE, TEST, READY, #, and CHIME) for approximately 5 seconds and then releasing it. Abbreviated instructions relative to the key that has been pressed will then be displayed (2 lines of text are displayed at a time). This function operates in either the armed or the disarmed state.

Displaying Descriptors

The Alpha Consoles can display all programmed descriptors, which is useful to the installer when checking entries, and can be helpful to the user when there is a need to identify zones. To display descriptors, press and hold the READY key until the built-in instructions for that key appear, then release the key. The zone descriptors will appear one at a time, for about 2-3 seconds each. For faster viewing, press the READY key to display the next descriptor in numerical order and so on. When all descriptors have been displayed, the Control will exit display mode. To exit display mode before all descriptors have been displayed, enter the security code and press the OFF key.

Panic Keys

There are three panic key pairs (shown below) that, if programmed, can be used to manually initiate alarms and send a report to the central station. Each key pair can be individually programmed for 24 Hour Silent, Audible or Auxiliary (Emergency) responses. The panic function is activated when the appropriate key pair is pressed at the same time.

The panic functions are identified by the system as follows:

<u>PANIC</u>	<u>Displayed as Zone</u>	
[*] + [1]	95	For 5137AD consoles, these panic keys can also be
[#] + [3]	96	programmed with an alpha descriptor.
[*] + [#]	99	

IMPORTANT: For the Panic functions to be of practical value, the system must be connected to a central station.

Trouble Conditions

The word "CHECK" on the Console's display, accompanied by a rapid "beeping" at the Console, indicates that there is a trouble condition in the system. The audible warning sound can be silenced by pressing any key. Instruct users to call for service immediately upon seeing any of the following messages.

"Check" Messages

- A display of "CHECK" accompanied by a display of one or more zone descriptor(s) indicates that a problem exists with those zone(s). First, determine if the zone(s) displayed are intact and make them so if they are not. If the problem has been corrected, key an OFF sequence (Code plus OFF) to clear the display.
- A display of the word "CHECK" accompanied by a numeric display of "97" indicates that a short exists on the Polling Loop and may eliminate some of the protection. Fault "97" can be assigned an alpha descriptor when using the 5137AD console.
- A display of the word "CHECK" accompanied by a numeric display of "88", "89", "90", or "91" indicates a 4280 Receiver problem. Faults "88", "89", "90" & "91" can be assigned alpha descriptors when using the 5137AD console.
- A display of "COMM. FAILURE" (5137AD) or "FC" (4137AD) at the Console indicates that a failure occurred in the telephone communication portion of your system.
- A display of "LO BAT" (5137AD) or "BAT" (4137AD) and a zone descriptor, accompanied by a once per minute beep at the Console indicates that a low battery condition exists in the wireless transmitter displayed. The audible warning sound may be silenced by pressing any key. A display of "SYSTEM LO BAT" (5137AD) or "BAT" with no zone number (4137AD) indicates that a low battery condition exists with the system's backup battery.
- A display of "RCVR SET UP ERROR" (5137AD) or "E8" (4137AD) at the console indicates that the system has more RF zones programmed than the RF receiver can support. If this is not corrected, none of the zones in the system will be protected. If more than 8 RF zones are desired, use a Receiver that supports more than 8 zones (4280, 4281H, 5881H).
- A display of "MODEM COMM" (5137AD) or "CC" (4137AD) indicates that the control is on-line with the remote computer and the control is not operating. Panel's response to alarm and trouble conditions will be delayed until on-line session is completed.

Other Trouble Conditions

Power Failure

If the POWER indicator is off, and the message "AC LOSS" (5137AD) or "NO AC" (4137AD) is displayed, the Console is operating on battery power only. Check to see that your system's plug-in transformer has not been accidentally pulled out. Instruct the user to call a service representative immediately if AC power cannot be restored.

Section 7. EVENT LOGGING & DIRECT WIRE DOWNLOADING (CONNECTOR J8)

EVENT LOGGING

Event Logging Printer Connections

Connector J8, located above connector J7 on the right side of the main PC board, is intended to be interfaced to a local serial printer via the 4100SM serial interface module, in applications where it is desired to print the event log on a local printer.

Mount the 4100SM using its clip bracket to attach it to the side wall of the control cabinet. Make connections between J8, the 4100SM module and the serial printer as shown below. Refer to the event logging commands paragraph for a description of the console commands which initiate event log printing.

NOTE 1: Printer must be configured as follows:

- 8 data bits, no parity, 1 stop bit
- 300 or 1200 baud (1200 preferred)
- Hardware handshaking using DTR signal

NOTE 2: The 4100SM module is supplied with a 10 foot RS232 cable. A longer cable or an extension cable can be used if the 4140XMPT2 and serial printer are separated by more than 10 feet, but the total cable length should be less than 50 feet.

NOTE 3: Most printers either ignore the CTS, DSR and CD signals, or require them to be high (i.e. 3-15VDC as measured on RS232 DB25 connector pins 5, 6 & 8 respectively with respect to ground pin 7). The 4100SM module sets these pins high. If the printer being used will not operate with these pins high, then clip the blue (CTS), white (DSR) or red (CD) jumpers on the 4100SM module to set the corresponding signal floating. Important pins on the RS232C cable are pin 3 (data out), pin 7 (ground) and pin 20 (DTR - ready).

NOTE 4: The DTR signal, as measured at 4100SM TB1, should be high (9.5-14VDC) when the printer is powered, properly connected, on-line and ready to print. This signal will be low (0-1.5VDC) when the printer is not powered, not properly connected, off-line or out of paper. The 4140XMPT2 will not send printing data to the printer unless the DTR signal is high.

UL NOTE: A UL Listed EDP printer must be used for UL installations.

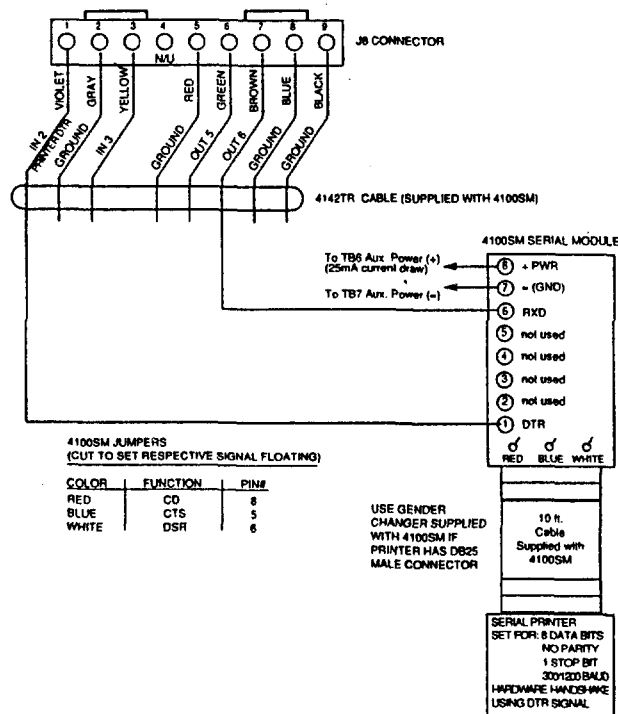

Event Logging Procedures

IMPORTANT: In order for time and date stamping to occur, the system's real-time clock must be set. Refer to the **SETTING THE REAL TIME CLOCK** section.

The system has the ability to record various events in a history log (224 event capacity) wherein each event is recorded in one of five categories (alarm, check, bypass, open & system), with the time and date of its occurrence (if real-time clock is set). The log may be viewed (Display Mode) using an alpha console, or can be printed (Print Mode) on a serial printer (connected to the system via a 4100SM Serial Module).

EVENT LOG MODE COMMANDS	
Display Mode (Installer or master):	Enter CODE + [#] + [6] + [0]
Print Mode (Installer only):	Enter CODE + [#] + [6] + [1]
Clear Event Log (Installer only):	Enter CODE + [#] + [6] + [2]
To EXIT Event Log Mode:	Press [Q] at any time.

Programming

The system can be configured for the following event log activities:

- To either record events but not print them unless commanded to do so, or to automatically print the events as they occur (field 1*72).
- Specific categories of events to be logged can be selectively enabled (field 1*70).
- The time stamp can be programmed for either 12 or 24 hour formats (field 1*71).
- The printer baud rate can be set to either 300 or 1200 baud (field 1*73).
- Set event log time/date report enable (fields 1*40 & 1*41).
- Enable reporting of event log capacity (i.e.. 50% full, 90% full & overflow) programmed in fields 1*40 & 1*41.

Event Logging Display & Print Modes

After entering event log mode, the following will be displayed:

ENTER 0 = RECENT 1 = COMPLETE

The Event Log holds up to 224 events, and can display or print all events in a category (complete), or only those events in a category occurring since the last Clear Event Log command (recent). Note that once the Event Log is full, the oldest event will be erased upon the logging of any new event. Press the desired display mode key, 0 or 1.

SCAN LOG BY PART 0=NO 1-8=PART #

The system allows viewing of any partition's event log. Enter the partition number for the partition whose events are to be displayed. Entering 0 (NO) will display all events that occurred in the system regardless of partition.

For display and printing purposes, events are stored on a partition by partition basis (except system events), and are grouped into five categories as follows.

Use the [3] & [1] keys to scroll to the next or previous category screens respectively:

ALARM EVENT LOG TYPE CCC UUU
CHECK EVENT LOG TYPE CCC UUU
BYPASS EVENT LOG TYPE CCC UUU
OP/CL EVENT LOG TYPE CCC UUU
SYSTEM EVENT LOG TYPE CCC UUU
ALL EVENT LOG TYPE CCC UUU

Displays time/date for zones that have either caused an alarm or have been restored in selected partition.

Displays time/date for zones that have caused a trouble or supervisory condition in selected partition.

Displays time/date for zones that have been bypassed in selected partition.

Displays time, date and user number for each arming and disarming of the system for the partition selected.

Displays time/date for system problems, such as AC Loss, communication failure, etc., regardless of partition.

Displays all categories of events in chronological order, from most recent to oldest.

To display the events in a particular category, press [8] at the desired category screen.

If in Display Mode, events will appear one at a time from the most recent to the oldest. Press [8] again to display each subsequent event.

If in Print Mode, the first press of [8] will cause the printer to print all events in that category, with each event automatically scrolled on the display console. The following is a typical display:

P8 01/01 12:02AM	Shows burglary alarm occurred in zone 3 of partition 8, at 12:02AM on January 1.
BURGLARY C03	

After the last event in the selected category has been displayed, the following will appear for a few seconds:

END OF EVENT LOG
TYPE CCC UUU

The system will automatically return to the RECENT/COMPLETE selection screen described earlier.

Clear Event Log

To clear the Event Log, enter installer code + [#] + [6] + [2]

The following will appear:

CLEAR EVENT LOG
0=NO 1=YES

Press [1] if Event Log is to be cleared from memory. All events in the log will still be displayed if the COMPLETE option is selected. Only those events occurring from the time of the CLEAR command will be displayed if RECENT display option is selected. Press [0] if event log is not to be cleared at this time.

If [1] is pressed, the following will appear:

ARE YOU SURE?
0=NO 1=YES

Press [1] if it is desired to clear the event log. Press [0] if event log is not to be cleared.

Screen Definitions

RECENT	Events since last CLEAR
COMPLETE	Displays all events
TYPE	Type of event (Burg., Fire, etc.)
CCC	Zone (contact) number
UUU	User number

DIRECT WIRE DOWNLOADING

Direct Wire Downloading Connections

The 4140XMPT2 can be downloaded without using a modem or telephone line by using 4130PC Downloading Software and a 4100SM Serial Module. The direct wire downloading connection is to be temporary, and is not part of the permanent installation. Direct wire downloading is meant as a tool for the installer during the installation process.

IMPORTANT: The connections between the 4140XMPT2 and the 4100SM are different than those shown in the 4100SM Installation Instructions. See diagram below for correct connections. In addition, when the "green" wire is referred to in step 2 of the IN CASE OF DIFFICULTY section of the 4100SM Instructions, use the "violet" wire.

Connector J8, located above connector J7 on the right hand side of the main PC board, is intended to be interfaced to either a local serial printer (see EVENT LOGGING CONNECTIONS) or a computer. Make connections to a computer as shown below. **Note that the violet wire connection for a computer differs from that used when connecting a serial printer.**

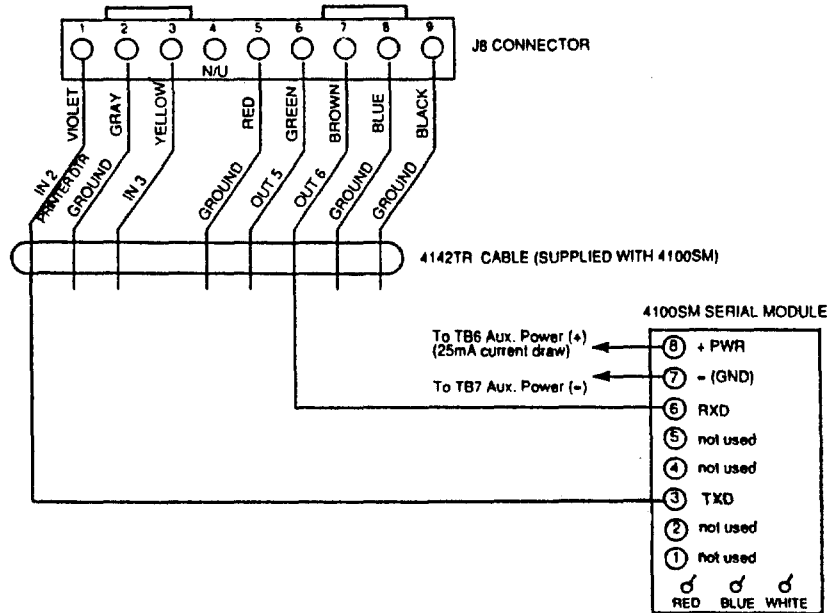

Section 8. SYSTEM COMMUNICATION

Split/Dual Reporting

Dual reporting (*51) sends all reports to both primary and secondary phone numbers. Split reporting allows reports to be divided between the phone numbers according to the field's (1*34) selections. Split/Dual reporting can be selected by enabling dual reporting and enabling one of the split reporting options in field 1*34. If option [1] is selected, all alarms, alarm restores and cancel reports will go to both phone numbers, while all other reports will go to the secondary phone number. If [2] is selected, open/close and test messages will go to both phone numbers, while all other reports will go to the primary phone number. Following are the Split/Dual Reporting options:

Reporting Format	Field Number		Where Reports Go
	*51	1*34	
Dual	1	0	All reports to both num.
Split	0	1 or 2	1=alarm, alarm restore & cancel to primary, all others to secondary. 2=open/close, test to secondary, all others to primary.
Split/Dual	1	1 or 2	1=alarm, alarm restore & cancel to both, all others to secondary only. 2=open/close to both, all others to primary only.

Ademco Low Speed

ADEMCO LOW SPEED is a pulsed format which responds to a 1400 Hz handshake and kiss-off, and transmits data with 1900Hz pulse tones @ 10 pulses per second (pps). A typical message consists of two rounds which must be verified by the receiver. A complete standard report consists of either a 3 or 4-digit account number followed by a 1-digit alarm code. Though 2 rounds are sent, only the valid report is displayed.

In expanded reporting, two messages are sent, two rounds per message, the first being the account number and alarm code, the second being the zone ID code to which the alarm was assigned. A complete expanded report consists of a 3 or 4-digit account number followed by a 1-digit alarm code, then the alarm code is repeated, followed by the channel number.

EX. Standard: CCCC E where: CCCC = account number
Expanded: CCCC E E = event code
EEEE Z Z = zone ID code

Sescoa/Radionics

Standard and expanded reporting in the SESCOA/RADIONICS format is virtually the same as ADEMCO Low Speed except for the following:

1. The handshake and kiss-off frequency is 2300 Hz.
2. The data is transmitted with 1800 Hz pulse tones.
3. The rate of transmission is 20 pps.

4+2 Reporting

A 4+2 report consists of a 4-digit account number and a 2-digit alarm code, or event code. 4+2 reports can be accomplished either in ADEMCO Low Speed (10 pps), or SESCOA/RADIONICS (20 pps) format.

In 4+2 reporting a unique 2-digit code for each zone is reported. A 4-digit account number followed by a 2-digit code is sent, where the first digit is the actual event, such as in ALARM, RESTORE, or TROUBLE, etc., and the second digit of the code represents the "zone" where the event occurred. (but not necessarily the actual zone number). Each code in itself is unique to a specific zone. If desired, the actual zone number can be reported by entering the corresponding 2-digit zone number (ex. zone 1= [0] [1]; zone 63= [6] [3]). A report might appear as:

1 2 3 4 5 9 ("5 9" might be a unique "TROUBLE RESTORE, ZONE 25).

4+2 Express

ADEMCO's Express format provides the same information as the 4+2 format, but with three differences:

1. The data is transmitted in DTMF (Dual Tone Multi-Frequency, known as "TouchTone", at the rate of 10 characters per second). This greatly decreases the time it takes a report to go through to central station. An average 4+2 Low Speed report might take as long as 20 seconds to complete its report, but 4+2 Express takes under 3 secs.
2. Two message rounds are eliminated by the use of a checksum digit. Instead of the communicator sending 2 rounds per report, it sends only 1 round with a checksum digit at the end. Doing this also helps in decreasing the time it takes for a report to be sent.
3. The handshake frequency is 1400 Hz followed by 2300 Hz, and the kiss-off frequency is 1400 Hz.

Ademco High Speed Reporting

ADEMCO's High Speed format transmits data in DTMF at a rate of 10 characters per second. The handshake frequency is 1400 Hz followed by 2300 Hz, and the kiss-off frequency is 1400 Hz. The message contains 13 digits as follows: A 4-digit account number + eight channels of zone information (1-8 or duress plus 9-15) + one status channel, which identifies the type of events being reported in the eight zone locations. A typical High Speed report will be kissed off in under 5 seconds.

Channels 1 through 8 could have one of the following conditions:

- 1 = NEW EVENT
- 2 = OPENING (Status Channel Always = 2)*
- 3 = RESTORE
- 4 = CLOSING (Status Channel Always = 4)*
- 5 = NORMAL, NO EVENT TO REPORT
- 6 = PREVIOUSLY REPORTED, NOT YET RESTORED

* NOTE: Channel 1 will contain the user ID 1-9, A-F if Open/Close reporting is enabled.

The status channel might have one of the following conditions:

- 1 = DURESS (For Duress Plus Channels 9-15 Only)
- 2 = OPENING
- 3 = BYPASS (For Channels 1-8 Only)
- 4 = CLOSING
- 5 = TROUBLE (For Channels 1-8 Only)
- 6 = SYSTEM STATUS:
 - AC LOSS in Channel 1
 - LOW BATTERY in Channel 2
 - PROGRAM TAMPER in Channel 3
 - POWER ON RESET in Channel 4
- 7 = NORMAL ALARM STATUS (Chnls 1-8 Only)
- 9 = TEST REPORT

A typical high speed report may look as follows:

1234 5115 5555 7 (Acct #1234 with alarms on channels 2 and 3)

High Speed Format Limitations

1. When using Ademco high speed, remember there are only 15 channels available, plus a duress channel. If more than 15 zones are being used, they will have to share channels.
2. With Ademco High Speed reporting, channels 9-15 cannot report troubles or bypasses. Use these channels for zones that will not report these conditions.

Contact ID Reporting

This is the only format that can identify all 87 protection zones by their unique zone (Contact) ID numbers, and provides a 1-digit event qualifier and 3-digit, specifically defined event code which quickly identifies the condition being reported.

Contact ID reports in DTMF (Dual Tone Multi-Frequency @ 10 characters per second) and responds to a 1400 Hz followed by 2300 Hz handshake, and a 1400 Hz kissoff. This format also uses checksum instead of two message verification. A complete report takes under 3 seconds.

Contact ID Reporting takes the format: CCCC Q EEE GG ZZZ where:

- CCCC = Customer (subscriber) number.
- Q = Event qualifier, where: E=new event (1) and R= restore (3)
- EEE = Event code (3 hexadecimal digits), defined in the table on the next page.
- GG = Partition number.
- ZZZ = Zone/contact ID number reporting the alarm (001-099), or user number (001-099) for open/close reports. System status messages (AC Loss, Walk Test, etc.) contain zeroes in the ZZZ location.

TABLE OF CONTACT ID EVENT CODES

Code	Definition	Code	Definition
110	Fire Alarm	401	O/C By User
121	Duress	403	Power-Up Armed
122	Silent Panic	406	Cancel by User
123	Audible Panic	407	Remote Arm/Disarm (Download)
131	Perimeter Burglary	408	Quick Arm
132	Interior Burglary	409	Keyswitch O/C
133	24 Hour Burglary	411	Call back Requested
134	Entry/Exit Burglary	441	Armed STAY
135	Day/Night Burglary	451	Early open/close
150	24 Hour Auxiliary	452	late open/close
301	AC Loss	453	Fail to open
302	Low System Battery	454	Fail to close
305	System Reset	455	Auto-arm fail
306	Program Tamper	570	Bypass
309	Battery Test Fail	602	Periodic Test
332	Poll Loop Short-Trouble	607	Walk Test Mode
333	RF Receiver Failure-Trouble	621	Event Log Reset
373	Fire Loop Trouble	622	Event Log 50% Full
380	Trouble (global)	623	Event Log 90% Full
381	Loss of Supervision - RF	624	Event Log Overflow
382	Loss of RPM Supervision	625	Time/Date Reset
383	RPM Sensor Tamper	626	Time/date inaccurate
384	RF Transmitter Low Battery	631	Exception schedule change
		632	Access schedule change

ADVISORY: Ademco's new Contact ID reporting is capable of uniquely reporting all 87 zones of information, as well as openings and closings for all 128 users, to central stations equipped with the Ademco 685 receiver using software level 4.4 or higher. Must be level 4.6 to fully support all new 4140XMPT2 report codes. 685 software levels below 4.4 cannot support Contact ID reporting. For information regarding updating the 685 receiver, contact the Technical Support group at 1-800-645-7492 (NY) or 1-800-458-9469 (CA)

Section 9. TESTING THE SYSTEM

Using Test Mode After the installation is completed, the Security System should be thoroughly tested on a partition by partition basis as follows:

1. With the System in the disarmed state, check that all zones are intact. If DISARMED - Press [*] to show faults is displayed, press the [*] key to display the descriptors of the faulted zone(s). Restore faulted zone(s) if necessary, so that ****DISARMED*** READY TO ARM is displayed.
2. Enter the security code and press the TEST key. The external sounder (if used) should sound for 3 seconds and then turn off (the system is operating on the back-up battery only at this time).

NOTE 1. If the sounder does not sound, this may be an indication that the backup battery is discharged or missing.

NOTE 2. As a reminder that the system is in the Test mode, the Console will sound a single beep at 15-second intervals if no protection zones are violated.

NOTE 3. In the Test mode, no alarm reports will be sent to the central station. Also, the external sounder (if used) will not be activated.

Doors and Windows

Open and close each protected door and window in turn. Each action should produce three beeps from the Console. The descriptor for each protection zone will appear on the Console display.

Motion Detectors

Walk in front of any interior motion detectors. Listen for three beeps when the detector senses movement. While it is activated, its descriptor will remain displayed on the Console. Note that wireless PIRs will have a 3 minute lockout between transmissions to conserve battery life (remove cover for walk test to override the 3-minute lock-out).

Smoke Detectors

Follow the test procedure provided by the manufacturer of each smoke detector to ensure that all detectors are operational and are functioning properly.

NOTE: A 2-wire smoke detector display will not clear until the Test mode is exited.

Turning Off TEST mode

Enter the security code and press the OFF key.

Armed System Test

IMPORTANT! A message will be sent to the central station during the following tests. Notify the central station that a test will be in progress.

NOTE: A display of "COMM. FAILURE" indicates a failure to communicate (no KISSOFF by the receiver at the central station after the maximum number of transmission attempts is tried). If this occurs, verify that the phone line is connected, the correct report format is programmed, etc.

1. Arm the system and fault one or more zones. Silence alarm sounder(s) each time by entering the code and pressing OFF. Check that Entry/Exit delay zones provide the assigned delay times.
2. Check the keypad-initiated alarms, if programmed in field *05, by pressing the Panic key pairs ([*] + [1], [#] + [3], [*] + [#]). If the system has been programmed for audible emergency, the console will emit a loud, steady alarm sound. The word ALARM and a descriptor "99" will be displayed for [*] + [#]. (if [*] + [1] is pressed, a "95" will be displayed; if [#] + [3] is pressed, a "96" will be displayed). Silence the alarm by entering the security code and pressing OFF. If the system has been programmed for silent panic, there will be no audible alarms or displays. A report will be sent to the central station, however.
3. Notify the central station that all tests are finished and verify results with them.

Turning The System Over To The User

1. Fully explain the operation of the system to the user by going over each of its functions as well as the User's Manual supplied.
2. In particular, explain the operation of each zone (entry/exit, perimeter, interior, fire, etc.). Be sure the user understands how to operate any emergency feature(s) programmed into the system.

IMPORTANT!: In the spaces provided in the User's Manual, record the Entry and Exit Delay times, and those functions that have been programmed into the available pairs of PANIC key pairs ([*] + [1], [#] + [3], [*] + [#]).

3. Make sure the user understands the importance of testing the system at least weekly, following the procedure provided in the User's Manual.

TO THE INSTALLER

Regular maintenance and inspection (at least annually) by the installer and frequent testing by the user are vital to continuous satisfactory operation of any alarm system.

The installer should assume the responsibility of developing and offering a regular maintenance program to the user as well as acquainting the user with the proper operation and limitations of the alarm system and its component parts. Recommendations must be included for a specific program of frequent testing (at least weekly) to insure the system's proper operation at all times.

Section 10. REGULATORY AGENCY STATEMENTS

UL INSTALLATION REQUIREMENTS

The following requirements apply to UL Residential Burglary installations:

1. All partitions must be owned and managed by the same person(s).
2. All partitions must be part of one building at one street address.
3. The audible alarm device(s) must be placed where it/they can be heard by all partitions.
4. The Control cabinet must be protected from unauthorized access. This can be done by installing a tamper switch on the cabinet door (not supplied with 4140XMPT2) or by installing a UL Listed passive infrared detector positioned to detect cabinet access. Wire the selected device to any EOLR supervised zone (zone 1-8). Program this zone for day trouble/night alarm (type 05) or 24 hour audible alarm (type 07) response. The 24 hour alarm response must be used for multiple partitioned systems.
5. Remote Downloading and auto-disarming are not UL Listed features.

"FEDERAL COMMUNICATIONS COMMISSION (FCC) STATEMENT"

This equipment has been tested to FCC requirements and has been found acceptable for use. The FCC requires the following statement for your information:

This equipment generates and uses radio frequency energy and if not installed and used properly, that is, in strict accordance with the manufacturer's instructions, may cause interference to radio and television reception. It has been type tested and found to comply with the limits for a Class B computing device in accordance with the specifications in Part 15 of FCC Rules, which are designed to provide reasonable protection against such interference in a residential installation. However, there is no guarantee that interference will not occur in a particular installation. If this equipment does cause interference to radio or television reception, which can be determined by turning the equipment off and on, the user is encouraged to try to correct the interference by one or more of the following measures:

- If using an indoor antenna, have a quality outdoor antenna installed.
- Reorient the receiving antenna until interference is reduced or eliminated.
- Move the receiver away from the control/communicator.
- Move the antenna leads away from any wire runs to the control/communicator.
- Plug the control/communicator into a different outlet so that it and the receiver are on different branch circuits.

If necessary, the user should consult the dealer or an experienced radio/television technician for additional suggestions.

The user or installer may find the following booklet prepared by the Federal Communications Commission helpful:

"Interference Handbook"

This booklet is available from the U.S. Government Printing Office, Washington, DC 20402.

The user shall not make any changes or modifications to the equipment unless authorized by the Installation Instructions or User's Manual. Unauthorized changes or modifications could void the user's authority to operate the equipment.

IN THE EVENT OF TELEPHONE OPERATIONAL PROBLEMS

In the event of telephone operational problems, disconnect the control panel by removing the plug from the RJ31X (CA38A in Canada) wall jack. We recommend that you demonstrate disconnecting the phones on installation of the system. Do not disconnect the phone connection inside the Control Panel. Doing so will result in the loss of your phone lines. If the regular phone works correctly after the Control Panel has been disconnected from the phone lines, the Control Panel has a problem and should be returned for repair. If upon disconnection of the Control Panel, there is still a problem on the line, notify the telephone company that they have a problem and request prompt repair service. The user may not under any circumstances (in or out of warranty) attempt any service or repairs to the system. It must be returned to the factory or an authorized service agency for all repairs.

FCC PART 68 NOTICE

This equipment complies with Part 68 of the FCC rules. On the front cover of this equipment is a label that contains, among other information, the FCC registration number and ringer equivalence number (REN) for this equipment. If requested, this information must be provided to the telephone company.

This equipment uses the following jacks:

An RJ31X is used to connect this equipment to the telephone network.

The REN is used to determine the quantity of devices which may be connected to the telephone line. Excessive RENs on the telephone line may result in the devices not ringing in response to an incoming call. In most, but not all areas, the sum of the RENs should not exceed five (5.0). To be certain of the number of devices that may be connected to the line, as determined by the total RENs, contact the telephone company to determine the maximum REN for the calling area.

If this equipment causes harm to the telephone network, the telephone company will notify you in advance that temporary discontinuance of service may be required. If advance notice is not practical, the telephone company will notify the customer as soon as possible. Also, you will be advised of your right to file a complaint with the FCC if you believe necessary.

The telephone company may make changes in its facilities, equipment, operations, or procedures that could affect the operation of the equipment. If this happens, the telephone company will provide advance notice in order for you to make the necessary modifications in order to maintain uninterrupted service.

If trouble is experienced with this equipment, please contact the manufacturer for repair and warranty information. If the trouble is causing harm to the telephone network, the telephone company may request you remove the equipment from the network until the problem is resolved.

There are no user serviceable components in this product, and all necessary repairs must be made by the manufacturer. Other repair methods may invalidate the FCC registration on this product.

This equipment cannot be used on telephone company-provided coin service. Connection to Party Line Service is subject to state tariffs.

This equipment is hearing-aid compatible.

When programming or making test calls to an emergency number, briefly explain to the dispatcher the reason for the call. Perform such activities in the off-peak hours; such as early morning or late evening.

CANADIAN DEPARTMENT OF COMMUNICATIONS (DOC) STATEMENT

NOTICE

The Canadian Department of Communications label identifies certified equipment. This certification means that the equipment meets certain telecommunications network protective, operational and safety requirements. The Department does not guarantee the equipment will operate to the user's satisfaction.

Before installing this equipment, users should ensure that it is permissible to be connected to the facilities of the local telecommunications company. The equipment must also be installed using an acceptable method of connection. In some cases, the company's inside wiring associated with a single line individual service may be extended by means of certified connector assembly (telephone extension cord). The customer should be aware that compliance with the above conditions may not prevent degradation of service in some situations.

Repairs to certified equipment should be made by an authorized Canadian maintenance facility designated by the supplier. Any repairs or alterations made by the user to this equipment, or equipment malfunctions, may give the telecommunications company cause to request the user to disconnect the equipment.

Users should ensure for their own protection that the electrical ground connections of the power utility, telephone lines and internal metallic water pipe system, if present, are connected together. This precaution may be particularly important in rural areas.

Caution: User should not attempt to make such connections themselves, but should contact the appropriate electric inspection authority, or electrician, as appropriate.

The Load Number (LN) assigned to each terminal device denotes the percentage of the total load to be connected to a telephone loop which is used by the device, to prevent overloading. The termination on a loop may consist of any combination of devices subject only to the requirement that the total of the Load Numbers of all the devices does not exceed 100.

AVIS

L'étiquette du ministère des Communications du Canada identifie le matériel homologué. Cette étiquette certifie que le matériel est conforme à certaines normes de protection, d'exploitation et de sécurité des réseaux de télécommunications. Le ministère n'assure toutefois pas que le matériel fonctionnera à la satisfaction de l'utilisateur.

Avant d'installer ce matériel, l'utilisateur doit s'assurer qu'il est permis de le raccorder aux installations de l'entreprise locale de télécommunications. Le matériel doit également être installé en suivant une méthode acceptée de raccordement. Dans certains cas, les fils intérieurs de l'entreprise utilisés pour un service individuel à la ligne unique peuvent être prolongés au moyen d'un dispositif homologué de raccordement (cordon prolongateur téléphonique interne). L'abonné ne doit pas oublier qu'il est possible que la conformité aux conditions énoncées ci-dessus n'empêche pas la dégradation du service dans certaines situations. Actuellement, les entreprises de télécommunications ne permettent pas que l'on raccorde leur matériel aux prises d'abonnés, sauf dans les cas précis prévus par les tarifs particuliers de ces entreprises.

Les réparations du matériel homologué doivent être effectuées par un centre d'entretien canadien autorisé désigné par le fournisseur. La compagnie de télécommunications peut demander à l'utilisateur de débrancher un appareil à la suite de réparations ou de modifications effectuées par l'utilisateur ou à cause de mauvais fonctionnement.

Pour sa propre protection, l'utilisateur doit s'assurer que tous les fils de mise en terre de la source d'énergie électrique, des lignes téléphoniques de réseau de conduites d'eau s'il y en a, soient raccordés ensemble. Cette précaution est particulièrement importante dans les régions rurales.

Avertissement: L'utilisateur ne doit pas tenter de faire ces raccordements lui-même; il doit avoir recours à un service d'inspection des installations électriques, ou à un électricien, selon le cas.

L'indice de charge (IC) assigné à chaque dispositif terminal pour éviter toute surcharge indique le pourcentage de la charge totale qui peut être raccordé à un circuit téléphonique bouclé utilisé par ce dispositif. La terminaison du circuit bouclé peut être constituée de n'importe quelle combinaison de dispositifs, pourvu que la somme des indices de charge de l'ensemble des dispositifs ne dépasse pas 100.

DIP SWITCH TABLES FOR ADDRESSABLE CONSOLES AND POLLING LOOP DEVICES

Addressable Consoles
(e.g. 5137AD)

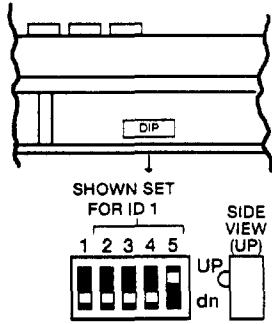

↑ **IMPORTANT:** USE ID 31 FOR APPLICATIONS NOT REQUIRING ADDRESSABLE CONSOLES.

4208 Zone Expander

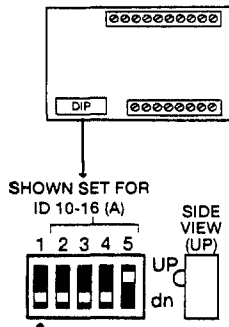

SHOWN SET FOR ID 10-16 (A)

POS. 1: LOOPS 1 & 2
RESPONSE TIME:
W/TABLE FAST SLOW
A UP dn
B dn UP

4196PIR

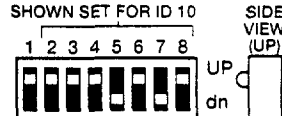
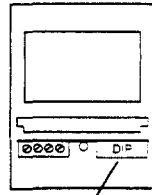

SHOWN SET FOR ID 10

POS. 1: MUST BE UP

4275 PIR

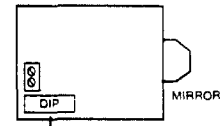

SHOWN SET FOR ID 10 (A)

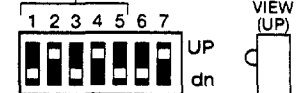

POS. 6: UP (A), dn (B) = INST. MODE
dn (A), UP (B) = PULSE COUNT
POS. 7: UP (A), dn (B) = WALK TEST
dn (A), UP (B) = W/T DISABLE

DEVICE ID	DIP SWITCH POSITION				
	1	2	3	4	5
0	dn	dn	dn	dn	dn
1	dn	dn	dn	dn	UP
2	dn	dn	dn	UP	dn
3	dn	dn	dn	UP	UP
4	dn	dn	UP	dn	dn
5	dn	dn	UP	dn	UP
6	dn	dn	UP	UP	dn
7	dn	dn	UP	UP	UP
8	dn	UP	dn	dn	dn
9	dn	UP	dn	dn	UP
10	dn	UP	dn	UP	dn
11	dn	UP	dn	UP	UP
12	dn	UP	UP	dn	dn
13	dn	UP	UP	dn	UP
14	dn	UP	UP	UP	dn
15	dn	UP	UP	UP	UP
16	UP	dn	dn	dn	dn
17	UP	dn	dn	dn	UP
18	UP	dn	dn	UP	dn
19	UP	dn	dn	UP	UP
20	UP	dn	UP	dn	dn
21	UP	dn	UP	dn	UP
22	UP	dn	UP	UP	dn
23	UP	dn	UP	UP	UP
24	UP	UP	dn	dn	dn
25	UP	UP	dn	dn	UP
26	UP	UP	dn	UP	dn
27	UP	UP	dn	UP	UP
28	UP	UP	UP	dn	dn
29	UP	UP	UP	dn	UP
30	UP	UP	UP	UP	dn
31	UP	UP	UP	UP	UP

↑ BIT VALUE: 16 8 4 2 1

THIS TABLE FOR DIPS WITH WORD "OFF" **A**

DEVICE ID	DIP SWITCH POSITION			
	2	3	4	5
10-16	dn	dn	dn	UP
17-24	dn	dn	UP	dn
25-32	dn	dn	UP	UP
33-40	dn	UP	dn	dn
41-48	dn	UP	dn	UP
49-56	dn	UP	UP	dn
57-64	dn	UP	UP	UP
65-72	UP	dn	dn	dn
73-80	UP	dn	dn	UP
81-88	UP	dn	UP	dn

THIS TABLE FOR DIPS WITH WORD "ON" **B**

DEVICE ID	DIP SWITCH POSITION			
	2	3	4	5
10-16	UP	UP	UP	dn
17-24	UP	UP	dn	UP
25-32	UP	UP	dn	dn
33-40	UP	dn	UP	UP
41-48	UP	dn	UP	dn
49-56	UP	dn	dn	UP
57-64	UP	dn	dn	dn
65-72	dn	UP	UP	UP
73-80	dn	UP	UP	dn
81-88	dn	UP	dn	UP

DIP SWITCH POSITION

DEVICE ID	DIP SWITCH POSITION							
	2	3	4	5	6	7	8	
10	UP	UP	UP	dn	UP	dn	UP	
11	UP	UP	UP	dn	UP	dn	dn	
12	UP	UP	UP	dn	dn	UP	dn	
13	UP	UP	UP	dn	dn	UP	dn	
14	UP	UP	UP	dn	dn	dn	UP	
15	UP	UP	UP	dn	dn	dn	dn	
16	UP	UP	dn	UP	UP	UP	UP	
17	UP	UP	dn	UP	UP	dn	dn	
18	UP	UP	dn	UP	UP	dn	dn	
19	UP	UP	dn	UP	UP	dn	dn	
20	UP	UP	dn	UP	UP	dn	dn	
21	UP	UP	dn	UP	UP	dn	dn	
22	UP	UP	dn	UP	UP	dn	dn	
23	UP	UP	dn	UP	UP	dn	dn	
24	UP	UP	dn	UP	UP	dn	dn	
25	UP	UP	dn	UP	UP	dn	dn	
26	UP	UP	dn	UP	UP	dn	dn	
27	UP	UP	dn	UP	UP	dn	dn	
28	UP	UP	dn	UP	UP	dn	dn	
29	UP	UP	dn	UP	UP	dn	dn	
30	UP	UP	dn	UP	UP	dn	dn	
31	UP	UP	dn	UP	UP	dn	dn	
32	UP	UP	dn	UP	UP	dn	dn	
33	UP	UP	dn	UP	UP	dn	dn	
34	UP	UP	dn	UP	UP	dn	dn	
35	UP	UP	dn	UP	UP	dn	dn	
36	UP	UP	dn	UP	UP	dn	dn	
37	UP	UP	dn	UP	UP	dn	dn	
38	UP	UP	dn	UP	UP	dn	dn	
39	UP	UP	dn	UP	UP	dn	dn	
40	UP	UP	dn	UP	UP	dn	dn	
41	UP	UP	dn	UP	UP	dn	dn	
42	UP	UP	dn	UP	UP	dn	dn	
43	UP	UP	dn	UP	UP	dn	dn	
44	UP	UP	dn	UP	UP	dn	dn	
45	UP	UP	dn	UP	UP	dn	dn	
46	UP	UP	dn	UP	UP	dn	dn	
47	UP	UP	dn	UP	UP	dn	dn	
48	UP	UP	dn	UP	UP	dn	dn	
49	UP	UP	dn	UP	UP	dn	dn	
50	UP	UP	dn	UP	UP	dn	dn	
51	UP	UP	dn	UP	UP	dn	dn	
52	UP	UP	dn	UP	UP	dn	dn	
53	UP	UP	dn	UP	UP	dn	dn	
54	UP	UP	dn	UP	UP	dn	dn	
55	UP	UP	dn	UP	UP	dn	dn	
56	UP	UP	dn	UP	UP	dn	dn	
57	UP	UP	dn	UP	UP	dn	dn	
58	UP	UP	dn	UP	UP	dn	dn	
59	UP	UP	dn	UP	UP	dn	dn	
60	UP	UP	dn	UP	UP	dn	dn	
61	UP	UP	dn	UP	UP	dn	dn	
62	UP	UP	dn	UP	UP	dn	dn	
63	UP	UP	dn	UP	UP	dn	dn	
64	UP	UP	dn	UP	UP	dn	dn	
65	UP	UP	dn	UP	UP	dn	dn	
66	UP	UP	dn	UP	UP	dn	dn	
67	UP	UP	dn	UP	UP	dn	dn	
68	UP	UP	dn	UP	UP	dn	dn	
69	UP	UP	dn	UP	UP	dn	dn	
70	UP	UP	dn	UP	UP	dn	dn	
71	UP	UP	dn	UP	UP	dn	dn	
72	UP	UP	dn	UP	UP	dn	dn	
73	UP	UP	dn	UP	UP	dn	dn	
74	UP	UP	dn	UP	UP	dn	dn	
75	UP	UP	dn	UP	UP	dn	dn	
76	UP	UP	dn	UP	UP	dn	dn	
77	UP	UP	dn	UP	UP	dn	dn	
78	UP	UP	dn	UP	UP	dn	dn	
79	UP	UP	dn	UP	UP	dn	dn	
80	UP	UP	dn	UP	UP	dn	dn	
81	UP	UP	dn	UP	UP	dn	dn	
82	UP	UP	dn	UP	UP	dn	dn	
83	UP	UP	dn	UP	UP	dn	dn	
84	UP	UP	dn	UP	UP	dn	dn	
85	UP	UP	dn	UP	UP	dn	dn	
86	UP	UP	dn	UP	UP	dn	dn	
87	UP	UP	dn	UP	UP	dn	dn	
88	UP	UP	dn	UP	UP	dn	dn	
89	UP	UP	dn	UP	UP	dn	dn	

BIT VALUE: 64 32 16 8 4 2 1

THIS TABLE FOR DIPS WITH WORD "OFF" **A**

DEVICE ID	DIP SWITCH POSITION				
	1	2	3	4	5
10	dn	UP	dn	UP	dn
11	dn	UP	dn	UP	UP
12	dn	UP	UP	dn	dn
13	dn	UP	UP	dn	UP
14	dn	UP	UP	dn	dn
15	dn	UP	UP	UP	UP
16	UP	dn	dn	dn	dn
17	UP	dn	dn	dn	UP
18	UP	dn	dn	UP	dn
19	UP	dn	dn	UP	UP
20	UP	dn	UP	dn	dn
21	UP	dn	UP	UP	dn
22	UP	dn	UP	UP	dn
23	UP	dn	UP	UP	UP
24	UP	UP	dn	dn	dn
25	UP	UP	dn	dn	UP
26	UP	UP	dn	UP	dn
27	UP	UP	dn	UP	UP
28	UP	UP	UP	dn	dn
29	UP	UP	UP	dn	UP
30	UP	UP	UP	UP	dn
31	UP	UP	UP	UP	UP

THIS TABLE FOR DIPS WITH WORD "ON" **B**

DEVICE ID	DIP SWITCH POSITION				
	1	2	3	4	5
10	UP	dn	UP	dn	UP
11	UP	dn	UP	dn	dn
12	UP	dn	dn	UP	UP
13	UP	dn	dn	UP	dn
14	UP	dn	dn	dn	UP
15	UP	dn	dn	dn	dn
16	dn	UP	UP	UP	UP
17	dn	UP	UP	UP	dn
18	dn	UP	UP	dn	UP
19	dn	UP	UP	dn	dn
20	dn	UP	dn	UP	UP
21	dn	UP	dn	UP	dn
22	dn	UP	dn	dn	UP
23	dn	UP	dn	dn	dn
24	dn	dn	UP	UP	UP
25	dn	dn	UP	UP	dn
26	dn	dn	UP	dn	UP
27	dn	dn	UP	dn	dn
28	dn	dn	dn	UP	UP
29	dn	dn	dn	UP	dn
30	dn	dn	dn	dn	UP
31	dn	dn	dn	dn	dn

BIT VALUE: 16 8 4 2 1

4192SD/4192SDT/
4192CP
Smoke Detectors

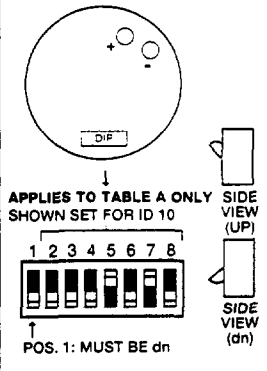

4190WH Zone Expander

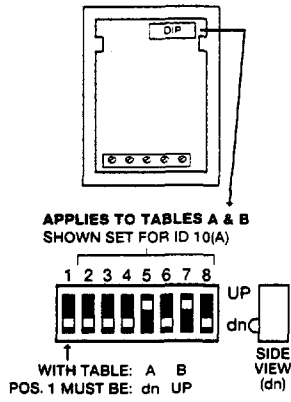

4278 PIR

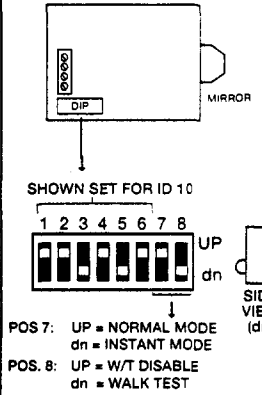

4194 Reed Contact
(Surface Mount)

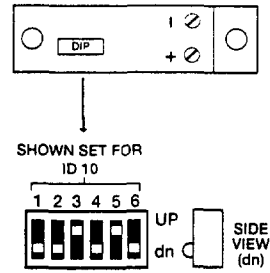

THIS TABLE FOR DIPS WITH
WORD "OFF"

A

DEVICE ID	DIP SWITCH POSITION							
	1	2	3	4	5	6	7	8
10	dn	dn	dn	UP	dn	UP	dn	UP
11	dn	dn	dn	UP	dn	UP	dn	UP
12	dn	dn	dn	UP	UP	dn	dn	UP
13	dn	dn	dn	UP	UP	dn	dn	UP
14	dn	dn	dn	UP	UP	UP	dn	UP
15	dn	dn	dn	UP	UP	UP	UP	UP
16	dn	dn	UP	dn	dn	dn	dn	dn
17	dn	dn	UP	dn	dn	dn	dn	UP
18	dn	dn	UP	dn	dn	UP	dn	UP
19	dn	dn	UP	dn	dn	UP	UP	UP
20	dn	dn	UP	dn	dn	UP	UP	UP
21	dn	dn	UP	dn	dn	UP	UP	UP
22	dn	dn	UP	dn	dn	UP	UP	dn
23	dn	dn	UP	dn	dn	UP	UP	UP
24	dn	dn	UP	dn	dn	UP	UP	dn
25	dn	dn	UP	dn	dn	UP	UP	dn
26	dn	dn	UP	dn	dn	UP	UP	dn
27	dn	dn	UP	dn	dn	UP	UP	dn
28	dn	dn	UP	dn	dn	UP	UP	dn
29	dn	dn	UP	dn	dn	UP	UP	dn
30	dn	dn	UP	dn	dn	UP	UP	dn
31	dn	dn	UP	dn	dn	UP	UP	dn
32	dn	dn	UP	dn	dn	UP	UP	dn
33	dn	dn	UP	dn	dn	UP	UP	dn
34	dn	dn	UP	dn	dn	UP	UP	dn
35	dn	dn	UP	dn	dn	UP	UP	dn
36	dn	dn	UP	dn	dn	UP	UP	dn
37	dn	dn	UP	dn	dn	UP	UP	dn
38	dn	dn	UP	dn	dn	UP	UP	dn
39	dn	dn	UP	dn	dn	UP	UP	dn
40	dn	dn	UP	dn	dn	UP	UP	dn
41	dn	dn	UP	dn	dn	UP	UP	dn
42	dn	dn	UP	dn	dn	UP	UP	dn
43	dn	dn	UP	dn	dn	UP	UP	dn
44	dn	dn	UP	dn	dn	UP	UP	dn
45	dn	dn	UP	dn	dn	UP	UP	dn
46	dn	dn	UP	dn	dn	UP	UP	dn
47	dn	dn	UP	dn	dn	UP	UP	dn
48	dn	dn	UP	dn	dn	UP	UP	dn
49	dn	dn	UP	dn	dn	UP	UP	dn
50	dn	dn	UP	dn	dn	UP	UP	dn
51	dn	dn	UP	dn	dn	UP	UP	dn
52	dn	dn	UP	dn	dn	UP	UP	dn
53	dn	dn	UP	dn	dn	UP	UP	dn
54	dn	dn	UP	dn	dn	UP	UP	dn
55	dn	dn	UP	dn	dn	UP	UP	dn
56	dn	dn	UP	dn	dn	UP	UP	dn
57	dn	dn	UP	dn	dn	UP	UP	dn
58	dn	dn	UP	dn	dn	UP	UP	dn
59	dn	dn	UP	dn	dn	UP	UP	dn
60	dn	dn	UP	dn	dn	UP	UP	dn
61	dn	dn	UP	dn	dn	UP	UP	dn
62	dn	dn	UP	dn	dn	UP	UP	dn
63	dn	dn	UP	dn	dn	UP	UP	dn
64	UP	dn	dn	dn	dn	dn	dn	dn
65	UP	dn	dn	dn	dn	dn	dn	dn
66	UP	dn	dn	dn	dn	dn	dn	dn
67	UP	dn	dn	dn	dn	dn	dn	dn
68	UP	dn	dn	dn	dn	dn	dn	dn
69	UP	dn	dn	dn	dn	dn	dn	dn
70	UP	dn	dn	dn	dn	dn	dn	dn
71	UP	dn	dn	dn	dn	dn	dn	dn
72	UP	dn	dn	dn	dn	dn	dn	dn
73	UP	dn	dn	dn	dn	dn	dn	dn
74	UP	dn	dn	dn	dn	dn	dn	dn
75	UP	dn	dn	dn	dn	dn	dn	dn
76	UP	dn	dn	dn	dn	dn	dn	dn
77	UP	dn	dn	dn	dn	dn	dn	dn
78	UP	dn	dn	dn	dn	dn	dn	dn
79	UP	dn	dn	dn	dn	dn	dn	dn
80	UP	dn	dn	dn	dn	dn	dn	dn
81	UP	dn	dn	dn	dn	dn	dn	dn
82	UP	dn	dn	dn	dn	dn	dn	dn
83	UP	dn	dn	dn	dn	dn	dn	dn
84	UP	dn	dn	dn	dn	dn	dn	dn
85	UP	dn	dn	dn	dn	dn	dn	dn
86	UP	dn	dn	dn	dn	dn	dn	dn
87	UP	dn	dn	dn	dn	dn	dn	dn
88	UP	dn	dn	dn	dn	dn	dn	dn
89	UP	dn	dn	dn	dn	dn	dn	dn

BIT VALUE: 64 32 16 8 4 2 1

THIS TABLE FOR DIPS
WITH WORD "ON"

B

DEVICE ID	DIP SWITCH POSITION							
	1	2	3	4	5	6	7	8
10	UP	UP	UP	dn	UP	dn	UP	dn
11	UP	UP	UP	dn	UP	dn	UP	dn
12	UP	UP	UP	dn	UP	dn	UP	UP
13	UP	UP	UP	dn	UP	dn	UP	UP
14	UP	UP	UP	dn	UP	dn	UP	UP
15	UP	UP	UP	dn	UP	dn	UP	UP
16	UP	UP	UP	dn	UP	dn	UP	UP
17	UP	UP	UP	dn	UP	dn	UP	UP
18	UP	UP	UP	dn	UP	dn	UP	UP
19	UP	UP	UP	dn	UP	dn	UP	UP
20	UP	UP	UP	dn	UP	dn	UP	UP
21	UP	UP	UP	dn	UP	dn	UP	UP
22	UP	UP	UP	dn	UP	dn	UP	UP
23	UP	UP	UP	dn	UP	dn	UP	UP
24	UP	UP	UP	dn	UP	dn	UP	UP
25	UP	UP	UP	dn	UP	dn	UP	UP
26	UP	UP	UP	dn	UP	dn	UP	UP
27	UP	UP	UP	dn	UP	dn	UP	UP
28	UP	UP	UP	dn	UP	dn	UP	UP
29	UP	UP	UP	dn	UP	dn	UP	UP
30	UP	UP	UP	dn	UP	dn	UP	UP
31	UP	UP	UP	dn	UP	dn	UP	UP
32	UP	UP	UP	dn	UP	dn	UP	UP
33	UP	UP	UP	dn	UP	dn	UP	UP
34	UP	UP	UP	dn	UP	dn	UP	UP
35	UP	UP	UP	dn	UP	dn	UP	UP
36	UP	UP	UP	dn	UP	dn	UP	UP
37	UP	UP	UP	dn	UP	dn	UP	UP
38	UP	UP	UP	dn	UP	dn	UP	UP
39	UP	UP	UP	dn	UP	dn	UP	UP
40	UP	UP	UP	dn	UP	dn	UP	UP
41	UP	UP	UP	dn	UP	dn	UP	UP
42	UP	UP	UP	dn	UP	dn	UP	UP
43	UP	UP	UP	dn	UP	dn	UP	UP
44	UP	UP	UP	dn	UP	dn	UP	UP
45	UP	UP	UP	dn	UP	dn	UP	UP
46	UP	UP	UP	dn	UP	dn	UP	UP
47	UP	UP	UP	dn	UP	dn	UP	UP
48	UP	UP	UP	dn	UP	dn	UP	UP
49	UP	UP	UP	dn	UP	dn	UP	UP
50	UP	UP	UP	dn	UP	dn	UP	UP
51	UP	UP	UP	dn	UP	dn	UP	UP
52	UP	UP	UP	dn	UP	dn	UP	UP
53	UP	UP	UP	dn	UP	dn	UP	UP
54	UP	UP	UP	dn	UP	dn	UP	UP
55	UP	UP	UP	dn	UP	dn	UP	UP
56	UP	UP	UP	dn	UP	dn	UP	UP
57	UP	UP	UP	dn	UP	dn	UP	UP
58	UP	UP	UP	dn	UP	dn	UP	UP
59	UP	UP	UP	dn	UP	dn	UP	UP
60	UP	UP	UP	dn	UP	dn	UP	UP
61	UP	UP	UP	dn	UP	dn	UP	UP
62	UP	UP	UP	dn	UP	dn	UP	UP
63	UP	UP	UP	dn	UP	dn	UP	UP
64	UP	UP	UP	dn	UP	dn	UP	UP
65	UP	UP	UP	dn	UP	dn	UP	UP
66	UP	UP	UP	dn	UP	dn	UP	UP
67	UP	UP	UP	dn	UP	dn	UP	UP
68	UP	UP	UP	dn	UP	dn	UP	UP
69	UP	UP	UP	dn	UP	dn	UP	UP
70	UP	UP	UP	dn	UP	dn	UP	UP
71	UP	UP	UP	dn	UP	dn	UP	UP
72	UP	UP	UP	dn	UP	dn	UP	UP
73	UP	UP	UP	dn	UP	dn	UP	UP
74	UP	UP	UP	dn	UP	dn	UP	UP
75	UP	UP	UP	dn	UP	dn	UP	UP
76	UP	UP	UP	dn	UP	dn	UP	UP
77	UP	UP	UP	dn	UP	dn	UP	UP
78	UP	UP	UP	dn	UP	dn	UP	UP
79	UP	UP	UP	dn	UP	dn	UP	UP
80	UP	UP	UP	dn	UP	dn	UP	UP
81	UP	UP	UP	dn	UP	dn	UP	UP
82	UP	UP	UP	dn	UP	dn	UP	UP
83	UP	UP	UP	dn	UP	dn	UP	UP
84	UP	UP	UP	dn	UP	dn	UP	UP
85	UP	UP	UP	dn	UP	dn	UP	UP
86	UP	UP	UP	dn	UP	dn	UP	UP
87	UP	UP	UP	dn	UP	dn	UP	UP
88	UP	UP	UP	dn	UP	dn	UP	UP
89	UP	UP	UP	dn	UP	dn	UP	UP

BIT VALUE: 64 32 16 8 4 2 1

9500 Glassbreak Detector

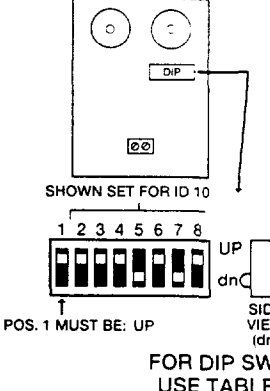

7500 Glassbreak Detector

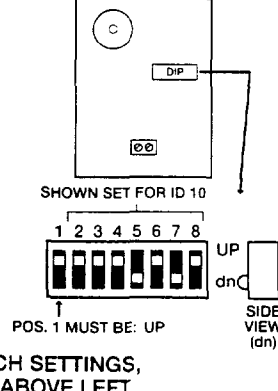

FOR DIP SWITCH SETTINGS,
USE TABLE B ABOVE LEFT

DIP SWITCH TABLES FOR WIRELESS DEVICES

House ID Switch Setting for All Devices Except 5716

HOUSE ID	1	2	3	4	5
1	UP	UP	UP	UP	dn
2	UP	UP	UP	dn	UP
3	UP	UP	dn	UP	dn
4	UP	UP	dn	UP	UP
5	UP	UP	dn	dn	UP
6	UP	UP	dn	dn	UP
7	UP	UP	dn	dn	dn
8	UP	dn	UP	UP	UP
9	UP	dn	UP	UP	dn
10	UP	dn	UP	dn	UP
11	UP	dn	UP	dn	dn
12	UP	dn	dn	UP	UP
13	UP	dn	dn	UP	dn
14	UP	dn	dn	dn	UP
15	UP	dn	dn	dn	dn
16	dn	UP	UP	UP	UP
17	dn	UP	UP	UP	dn
18	dn	UP	UP	dn	UP
19	dn	UP	UP	dn	dn
20	dn	UP	dn	UP	UP
21	dn	UP	dn	UP	dn
22	dn	UP	dn	dn	UP
23	dn	UP	dn	dn	dn
24	dn	dn	UP	UP	UP
25	dn	dn	UP	UP	dn
26	dn	dn	UP	dn	UP
27	dn	dn	UP	dn	dn
28	dn	dn	dn	UP	UP
29	dn	dn	dn	UP	dn
30	dn	dn	dn	dn	UP
31	dn	dn	dn	dn	dn

BIT VALUE: 16 | 8 | 4 | 2 | 1

5701 Panic Xmtr.

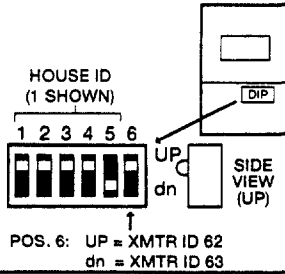

5727 Keypad

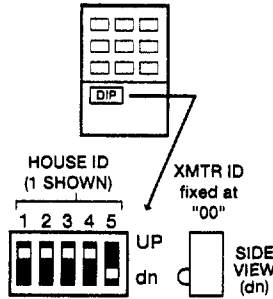

5706/5707 Smoke Detector Transmitter

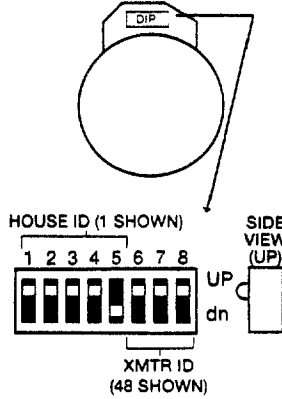

XMTR ID	6	7	8
48	UP	UP	UP
49	UP	UP	dn
50	UP	dn	UP
51	UP	dn	dn
52	dn	UP	UP
53	dn	UP	dn
54	dn	dn	UP
55	dn	dn	dn

5775 PIR Detector/Transmitter

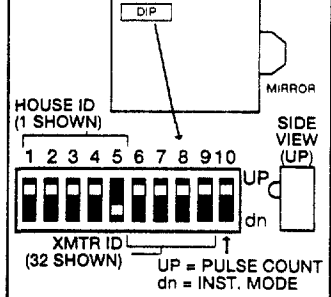

XMTR ID	DIP SWITCH SETTINGS			
6	7	8	9	
32	UP	UP	UP	dn
33	UP	UP	UP	UP
34	UP	UP	dn	UP
35	UP	UP	dn	dn
36	UP	dn	UP	UP
37	UP	dn	UP	dn
38	UP	dn	dn	UP
39	UP	dn	dn	dn
40	dn	UP	UP	UP
41	dn	UP	UP	dn
42	dn	UP	dn	UP
43	dn	UP	dn	dn
44	dn	dn	UP	UP
45	dn	dn	UP	dn
46	dn	dn	dn	UP
47	dn	dn	dn	dn

5715 Universal Xmtr.

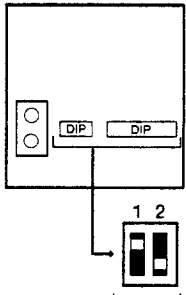

POS. 1: UP = NORMAL RESPONSE
dn = FAST RESPONSE
POS. 2: UP = NO COVER TAMPER
dn = COVER TAMPER (use N.C. setting)

XMTR ID	6	7	8	9	10	11
1	UP	UP	UP	UP	UP	dn
2	UP	UP	UP	UP	dn	UP
3	UP	UP	UP	dn	UP	dn
4	UP	UP	UP	dn	UP	UP
5	UP	UP	UP	dn	dn	UP
6	UP	UP	UP	dn	dn	dn
7	UP	UP	dn	UP	UP	UP
8	UP	UP	dn	UP	UP	dn
9	UP	UP	dn	UP	dn	UP
10	UP	UP	dn	UP	dn	dn
11	UP	UP	dn	UP	dn	dn
12	UP	UP	dn	dn	UP	UP
13	UP	UP	dn	dn	UP	dn
14	UP	UP	dn	dn	UP	dn
15	UP	UP	dn	dn	dn	UP
16	UP	UP	dn	dn	dn	dn
17	UP	dn	UP	UP	UP	dn
18	UP	dn	UP	UP	UP	dn
19	UP	dn	UP	UP	dn	UP
20	UP	dn	UP	UP	dn	dn
21	UP	dn	dn	UP	UP	UP
22	UP	dn	dn	UP	UP	dn
23	UP	dn	dn	UP	dn	UP
24	UP	dn	dn	UP	dn	dn
25	UP	dn	dn	UP	dn	dn
26	UP	dn	dn	UP	dn	dn
27	UP	dn	dn	UP	dn	dn
28	UP	dn	dn	UP	dn	dn
29	UP	dn	dn	UP	dn	dn
30	UP	dn	dn	UP	dn	dn
31	UP	dn	dn	UP	dn	dn
32	dn	UP	UP	UP	UP	UP

BIT VALUE: 32 | 16 | 8 | 4 | 2 | 1

5711/5711WM Door/Window Transmitter

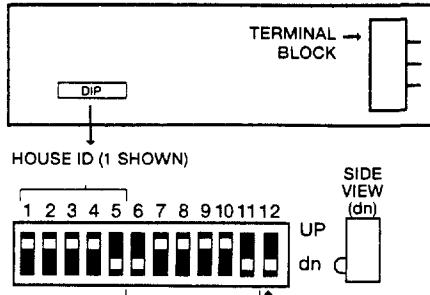

POS. 12: UP = N.O.
dn = N.C. (Avoid ID 32-37 with N.O.)

XMTR ID	6	7	8	9	10	11
33	dn	UP	UP	UP	UP	dn
34	dn	UP	UP	UP	dn	UP
35	dn	UP	UP	UP	dn	dn
36	dn	UP	UP	dn	UP	UP
37	dn	UP	UP	dn	UP	dn
38	dn	UP	UP	dn	dn	UP
39	dn	UP	UP	dn	dn	dn
40	dn	UP	dn	UP	UP	UP
41	dn	UP	dn	UP	UP	dn
42	dn	UP	dn	UP	dn	UP
43	dn	UP	dn	UP	dn	dn
44	dn	UP	dn	UP	dn	UP
45	dn	UP	dn	UP	dn	dn
46	dn	UP	dn	UP	dn	dn
47	dn	UP	dn	UP	dn	dn
48	dn	dn	UP	UP	UP	UP
49	dn	dn	UP	UP	UP	dn
50	dn	dn	UP	UP	dn	UP
51	dn	dn	UP	UP	dn	dn
52	dn	dn	UP	dn	UP	UP
53	dn	dn	UP	dn	UP	dn
54	dn	dn	UP	dn	dn	UP
55	dn	dn	UP	dn	dn	dn
56	dn	dn	dn	UP	UP	UP
57	dn	dn	dn	UP	UP	dn
58	dn	dn	dn	UP	dn	UP
59	dn	dn	dn	UP	dn	dn
60	dn	dn	dn	UP	dn	dn
61	dn	dn	dn	UP	dn	dn
62	dn	dn	dn	UP	dn	dn
63	dn	dn	dn	UP	dn	dn

BIT VALUE: 32 | 16 | 8 | 4 | 2 | 1

IMPORTANT SET SWITCHES WITH BATTERY REMOVED

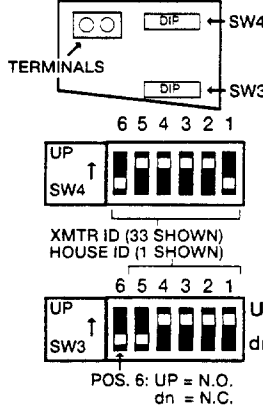

HOUSE ID	5	4	3	2	1
1	dn	UP	UP	UP	UP
2	UP	dn	UP	UP	UP
3	dn	dn	UP	UP	UP
4	UP	UP	dn	UP	UP
5	dn	UP	dn	UP	UP
6	UP	dn	dn	UP	UP
7	dn	dn	dn	UP	UP
8	UP	UP	UP	dn	UP
9	dn	UP	UP	dn	UP
10	UP	UP	dn	UP	UP
11	dn	UP	dn	UP	UP
12	UP	UP	dn	dn	UP
13	dn	UP	dn	dn	UP
14	UP	dn	dn	dn	UP
15	dn	dn	dn	dn	UP
16	UP	UP	UP	UP	dn
17	dn	UP	UP	UP	dn
18	UP	dn	UP	UP	dn
19	dn	dn	UP	UP	dn
20	UP	UP	dn	UP	dn
21	dn	UP	dn	UP	UP
22	UP	dn	dn	UP	UP
23	dn	dn	dn	UP	dn
24	UP	UP	dn	UP	dn
25	dn	UP	dn	UP	dn
26	UP	dn	dn	UP	dn
27	dn	UP	dn	UP	dn
28	UP	UP	UP	UP	dn
29	dn	UP	UP	UP	dn
30	UP	UP	UP	UP	dn
31	dn	UP	UP	UP	dn
32	dn	dn	dn	dn	dn

BIT VALUE: 1 | 2 | 4 | 8 | 16

5716 Door/Window Transmitter

TRANSMITTER ID	DIP SWITCH SETTINGS					
6	5	4	3	2	1	
1	dn	UP	UP	UP	UP	UP
2	UP	dn	UP	UP	UP	UP
3	dn	dn	UP	UP	UP	UP
4	UP	UP	dn	UP	UP	UP
5	dn	UP	dn	UP	UP	UP
6	UP	dn	dn	UP	UP	UP
7	dn	dn	dn	UP	UP	UP
8	UP	UP	UP	dn	UP	UP
9	dn	UP	UP	dn	UP	UP
10	UP	dn	UP	dn	UP	UP
11	dn	dn	UP	dn	UP	UP
12	UP	UP	dn	dn	UP	UP
13	dn	UP	dn	dn	UP	UP
14	UP	dn	dn	dn	UP	UP
15	dn	UP	UP	UP	dn	UP
16	UP	UP	UP	UP	dn	UP
17	dn	UP	UP	UP	dn	UP
18	UP	dn	UP	UP	dn	UP
19	dn	dn	UP	UP	dn	UP
20	UP	UP	dn	UP	dn	UP
21	dn	dn	UP	UP	dn	UP
22	UP	dn	dn	UP	dn	UP
23	dn	dn	dn	UP	dn	UP
24	UP	UP	UP	dn	UP	UP
25	dn	UP	UP	dn	UP	UP
26	UP	UP	dn	UP	dn	UP
27	dn	UP	UP	dn	dn	UP
28	UP	UP	dn	dn	UP	UP
29	dn	UP	dn	dn	UP	UP
30	UP	UP	dn	dn	UP	UP
31	dn	dn	dn	dn	UP	UP
32	UP	UP	UP	UP	UP	dn
33	dn	UP	UP	UP	UP	dn
34	UP	dn	UP	UP	UP	dn
35	dn	dn	UP	UP	UP	dn
36	UP	UP	dn	UP	UP	dn
37	dn	UP	dn	UP	UP	dn
38	UP	dn	dn	UP	UP	dn
39	dn	dn	dn	UP	UP	dn
40	UP	UP	UP	UP	dn	UP
41	dn	UP	UP	dn	UP	UP
42	UP	dn	UP	UP	dn	UP
43	dn	dn	UP	dn	UP	UP
44	UP	UP	dn	dn	UP	UP
45	dn	UP	dn	dn	UP	UP
46	UP	dn	dn	dn	UP	UP
47	dn	dn	dn	dn	UP	UP
48	UP	UP	UP	UP	dn	UP
49	dn	UP	UP	UP	dn	UP
50	UP	dn	UP	UP	dn	UP
51	dn	dn	UP	UP	dn	UP
52	UP	UP	dn	UP	dn	UP
53	dn	UP	dn	UP	dn	UP
54	UP	dn	dn	UP	dn	UP
55	dn	dn	dn	UP	dn	UP
56	UP	UP	UP	UP	dn	UP
57	dn	UP	UP	UP	dn	UP
58	UP	dn	UP	UP	dn	UP
59	dn	dn	UP	UP	dn	UP
60	UP	UP	UP	UP	dn	UP
61	dn	UP	UP	UP	dn	UP
62	UP	dn	UP	UP	dn	UP
63	dn	dn	dn	dn	dn	UP

BIT VALUE: 1 | 2 | 4 | 8 | 16 | 32

SUMMARY OF SYSTEM COMMANDS

Event Logging Commands	Event Log Display=Code+[#] + 60 Event Log Print=Code + [#] +61 (installer only) Clear Event Log Code + # + 62 (Installer Only)
Wireless System Commands	House Id Sniffer Mode=Code + [#] + 2 (installer only) Transmitter Id Test= Code + [#] + 3 (installer only) Go/No Go Test=Code + 5 (Test Key)
User Code Commands	Add A User Code=User Code + 8+ New User Number + New User's Code Change A Code=User Code + 8 + User Number + New User's Code Delete A User's Code=Your User Code + 8 + User Number To Be Deleted + Your Code Again View User Capability= User's Code + * + * Set Real-Time Clock (Installer, Master Only)=Code + # +63
Keypad Functions	Arming Away Enter Code + Away [2]. Arming Stay Enter Code + Stay [3]. Arming Instant Enter Code + Instant [7]. Arming Maximum Quick Arm Enter Code + Maximum [4]. Global Arming Use # Key Instead Of User Code Followed By Any Of The Above Arming Mode Keys. If Enabled For The User, The Console Will Display A Prompt. Answer The Prompted Questions Disarming Enter Code + Off [1]. Bypassing Zones Enter Code + Bypass [6] + Zone Number. To Automatically Bypass All Faulted Zones, Use Quick Bypass Chime Mode "Quick Bypass" Method: Enter Code + Bypass + [#]. Enter Code + Chime [9]. To Turn Chime Mode Off, Enter Code + Chime Again. Partition Goto= User Code + * + Partition Number 0-8 Goto Home Partition=User Code + * + 0 Panics *+1 Zone 95 (A Key) *+# Zone 99 (B Key) #+3 Zone 96 (C Key) View Downloaded Messages= Press 0 For 5 Seconds Display All Zone Descriptors=Press * For 5 Seconds Display User Self Help= Hold Any Key For 5 Seconds
Programming Commands	Site Initiated Download=User Code + # + 1 Direct Wire Download Enable= User Code + # + 5 Enter Program Mode=Installer Code + 800 Exit Program Mode=*99 Or *98
Scheduling Commands	Installer Programmed Schedule Events=Installer Code + # + 80 Temporary Schedule Editing=User Code + # + 81 (Installer, Master, Manager Only) Extend Closing Window=User Code + # + 82 (Installer, Master, Manager Only) End User Output Device Programming=User Code + # + 83
Device Control (X-10 Or Relay)	Activate Output Device As Programmed =User Code + # + 71 Activate Output Device As Programmed =User Code + # + 72 Activate Access Relay For Current Partition=User Code + 0

11. SPECIFICATIONS

4140XMPT2 CONTROL

Physical: 12-1/2"W X 14-1/2"H X 3"D

Electrical:

VOLTAGE INPUT: From Ademco No. 1361 Plug-In Transformer (use 1361CN in Canada) or 4300 transformer (for X-10 installations) rated 16.5VAC, 40 VA.

ALARM SOUNDER OUTPUT: 10VDC-13.8VDC, 2.8 amps max. (UL1023, UL609 installations), 750mA less aux. current draw (UL985 installations).

AUXILIARY POWER OUTPUT: 9.6VDC-13.8VDC, 750mA max. For UL installations, the accessories connected to the output must be UL Listed, and rated to operate in the above voltage range.

BACK-UP BATTERY: 12VDC, 4AH or 7AH gel cell. YUASA NP4-12 (12V, 4AH) or NP7-12 (12V, 7AH) recommended.

STANDBY: 4 hours min. with 750 mA aux. load using 7 AH battery.

CIRCUIT PROTECTORS: thermal circuit breakers are used on battery input to protect against reverse battery connections and on alarm sounder output to protect against wiring faults (Shorts). A solid state circuit breaker is used on auxiliary power output to protect against wiring faults (shorts).

DIGITAL COMMUNICATOR

FORMATS SUPPORTED:

ADEMCO HIGH SPEED
ADEMCO 4+2 EXPRESS
ADEMCO LOW SPEED
ADEMCO CONTACT ID
SESCOA
RADIONICS LOW SPEED
LINE SEIZE: Double Pole
RINGER EQUIVALENCE: 0.7B
FCC REGISTRATION NO.: AC398U-68192-AL-E

4137AD/5137AD REMOTE CONSOLES

Physical:

Width: 8.4 inches
Height: 4.75 inches
Depth: 1.1 inches

Electrical: Voltage Input: 12VDC
Current Drain: 60 mA (4137AD)
90 mA (5137AD)

Interface Wiring:

RED: 12VDC input (+) auxiliary power
BLUE: Not Used
GREEN: Data to control panel
YELLOW: Data from control panel
BLACK: Ground and (-) connection from supplemental power supply.

6139 Remote Console

Physical:

Width: 6.25 inches
Height: 4.75 inches
Depth: 1.25 inches

Electrical: Voltage Input: 12VDC
Current Drain: 100 mA

Interface Wiring:

RED: 12VDC input (+) auxiliary power
BLUE: Not Used
GREEN: Data to control panel
YELLOW: Data from control panel
BLACK: Ground and (-) connection from supplemental power supply.

WARNING: OWNER'S INSTRUCTION NOTICE NOT TO BE REMOVED WEEKLY TESTING IS REQUIRED TO ENSURE PROPER OPERATION OF THIS SYSTEM.

- NOTES:**
- Zone 1 may be selected for EOLR supervised or normally closed (no EOLR) operation via cut jumper. (Cut red jumper for normally closed operation. Do not cut for Fire Usage). Zones 2-8 may be selected for either operation via program field *41.
 - Zone 1 supports 2-wire smoke detectors. See Installation Instructions for recommended type and maximum number of detectors supported.
 - Zone 7 may be used for remote keyswitch arming/disarming. See Installation Instructions for wiring instructions.
 - Zone 8 supports 2-wire latching type glass break detectors. See Installation Instructions for recommended type and maximum number of detectors supported.

COMPLIES WITH FCC RULES, PART 68
 FCC REGISTRATION NO. AC398U-68192-AL-E
 RINGER EQUIVALENCE: 0.7B

THIS DEVICE COMPLIES WITH PART 15 OF FCC RULES. OPERATION IS SUBJECT TO THE FOLLOWING TWO CONDITIONS: (1) IT MAY NOT CAUSE HARMFUL INTERFERENCE. (2) IT MUST ACCEPT ANY INTERFERENCE THAT MAY CAUSE UNDESIRE OPERATION.

- J7 Header**
- Not Used
 - Ground
 - Out 1 (Ground Start)
 - Ground
 - Out 2 (fire)
 - Ground
 - Out 3 (burg/aud. panic)
 - Ground
 - Out 4 (silent panic/duress)
- J8 Header**
- In 2 (Printer DTR)
 - Ground
 - In 3 (4300 sync)
 - In 4 (4300 sync)
 - Ground
 - Out 5 (4300 data)
 - Out 6 (Printer RXD)
 - Ground
 - Ground
- Optional programming:
 Out 1: Open/close or console-like sounding
 Out 2: Armed LED
 Out 4: Ready LED
 Ratings for Out 1:
 Active: 10VDC-13.8VDC through 4k OHMS
 Not Active: 100 OHMS to ground
 Ratings for out 2-4:
 Active: 10VDC-13.8VDC through 5k OHMS
 Not Active: 1k OHMS to ground
- (Refer to Installation Instructions for information concerning Direct Wire Downloading and printer connections using the 4100SM Serial Module.)

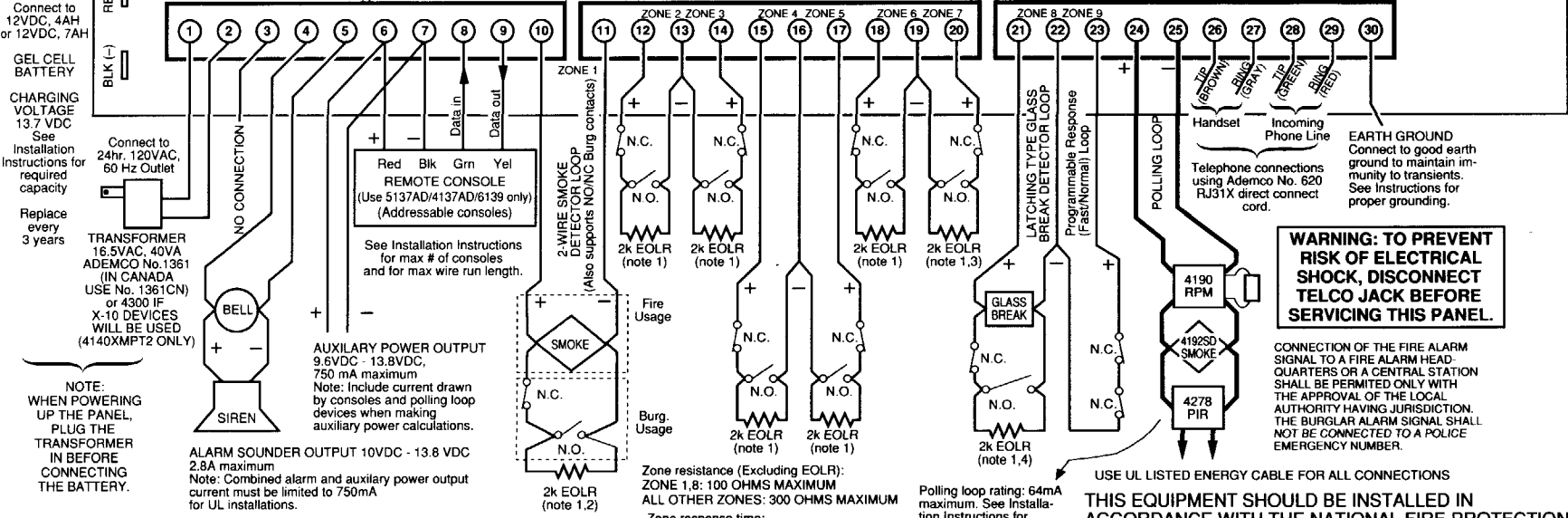
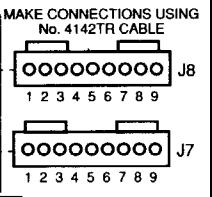

WARNING: TO PREVENT RISK OF ELECTRICAL SHOCK, DISCONNECT TELCO JACK BEFORE SERVICING THIS PANEL.

CONNECTION OF THE FIRE ALARM SIGNAL TO A FIRE ALARM HEAD QUARTERS OR A CENTRAL STATION SHALL BE PERMITTED ONLY WITH THE APPROVAL OF THE LOCAL AUTHORITY HAVING JURISDICTION. THE BURGLAR ALARM SIGNAL SHALL NOT BE CONNECTED TO A POLICE EMERGENCY NUMBER.

FOR COMPLETE INFORMATION, SEE INSTRUCTIONS
 N5944-2 for 4140XMPT2
 N5944V2 for 4140XMPT

COMPLIES WITH FCC RULES, PART 68
 FCC REGISTRATION NO. AC398U-68192-AL-E
 RINGER EQUIVALENCE: 0.7B

4140XMPT/4140XMPT2 SUMMARY OF CONNECTIONS
 DOC LOAD NO.: 5

USE UL LISTED ENERGY CABLE FOR ALL CONNECTIONS

Polling loop rating: 64mA maximum. See Installation Instructions for maximum number of devices supported and maximum wire run length.

THIS EQUIPMENT SHOULD BE INSTALLED IN ACCORDANCE WITH THE NATIONAL FIRE PROTECTION ASSOCIATION'S STANDARD 74 (NATIONAL FIRE PROTECTION ASSOC., BATTERY MARCH PARK, QUINCY, MA. 02269). PRINTED INFORMATION DESCRIBING PROPER INSTALLATION, OPERATION, TESTING, MAINTENANCE, EVACUATION PLANNING AND REPAIR SERVICE IS TO BE PROVIDED WITH THIS EQUIPMENT.

WARNING!
THE LIMITATIONS OF THIS ALARM SYSTEM

While this System is an advanced wireless security system, it does not offer guaranteed protection against burglary, fire or other emergency. Any alarm system, whether commercial or residential, is subject to compromise or failure to warn for a variety of reasons. For example:

- Intruders may gain access through unprotected openings or have the technical sophistication to bypass an alarm sensor or disconnect an alarm warning device.
- Intrusion detectors (e.g., passive infrared detectors), smoke detectors, and many other sensing devices will not work without power. Battery-operated devices will not work without batteries, with dead batteries, or if the batteries are not put in properly. Devices powered solely by AC will not work if their AC power supply is cut off for any reason, however briefly.
- Signals sent by wireless transmitters may be blocked or reflected by metal before they reach the alarm receiver. Even if the signal path has been recently checked during a weekly test, blockage can occur if a metal object is moved into the path.
- A user may not be able to reach a panic or emergency button quickly enough.
- While smoke detectors have played a key role in reducing residential fire deaths in the United States, they may not activate or provide early warning for a variety of reasons in as many as 35% of all fires, according to data published by the Federal Emergency Management Agency. Some of the reasons smoke detectors used in conjunction with this System may not work are as follows. Smoke detectors may have been improperly installed and positioned. Smoke detectors may not sense fires that start where smoke cannot reach the detectors, such as in chimneys, in walls, or roofs, or on the other side of closed doors. Smoke detectors also may not sense a fire on another level of a residence or building. A second floor detector, for example, may not sense a first floor or basement fire. Finally, smoke detectors have sensing limitations. No smoke detector can sense every kind of fire every time. In general, detectors may not always warn about fires caused by carelessness and safety hazards like smoking in bed, violent explosions, escaping gas, improper storage of flammable materials, overloaded electrical circuits, children playing with matches, or arson. Depending on the nature of the fire and/or location of the smoke detectors, the detector, even if it operates as anticipated, may not provide sufficient warning to allow all occupants to escape in time to prevent injury or death.
- Passive Infrared Motion Detectors can only detect intrusion within the designed ranges as diagrammed in their installation manual. Passive Infrared Detectors do not provide volumetric area protection. They do create multiple beams of protection, and intrusion can only be detected in unobstructed areas covered by those beams. They cannot detect motion or intrusion that takes place behind walls, ceilings, floors, closed doors, glass partitions, glass doors, or windows. Mechanical tampering, masking, painting or spraying of any material on the mirrors, windows or any part of the optical system can reduce their detection ability. Passive Infrared Detectors sense changes in temperature; however, as the ambient temperature of the protected area approaches the temperature range of 90° to 105°F (32° to 40°C), the detection performance can decrease.
- Alarm warning devices such as sirens, bells or horns may not alert people or wake up sleepers if they are located on the other side of closed or partly open doors. If warning devices are located on a different level of the residence from the bedrooms, then they are less likely to waken or alert people inside the bedrooms. Even persons who are awake may not hear the warning if the alarm is muffled by noise from a stereo, radio, air conditioner or other appliance, or by passing traffic. Finally, alarm warning devices, however loud, may not warn hearing-impaired people.
- Telephone lines needed to transmit alarm signals from a premises to a central monitoring station may be out of service or temporarily out of service. Telephone lines are also subject to compromise by sophisticated intruders.
- Even if the system responds to the emergency as intended, however, occupants may have insufficient time to protect themselves from the emergency situation. In the case of a monitored alarm system, authorities may not respond appropriately.
- This equipment, like other electrical devices, is subject to component failure. Even though this equipment is designed to last as long as 20 years, the electronic components could fail at any time.

The most common cause of an alarm system not functioning when an intrusion or fire occurs is inadequate maintenance. This alarm system should be tested weekly to make sure all sensors and transmitters are working properly. The security console (and remote keypad) should be tested as well.

Wireless transmitters (used in some systems) are designed to provide long battery life under normal operating conditions. Longevity of batteries may be as much as 4 to 7 years, depending on the environment, usage, and the specific wireless device being used. External factors such as humidity, high or low temperatures, as well as large swings in temperature, may all reduce the actual battery life in a given installation. This wireless system, however, can identify a true low battery situation, thus allowing time to arrange a change of battery to maintain protection for that given point within the system.

Installing an alarm system may make the owner eligible for a lower insurance rate, but an alarm system is not a substitute for insurance. Homeowners, property owners and renters should continue to act prudently in protecting themselves and continue to insure their lives and property.

We continue to develop new and improved protection devices. Users of alarm systems owe it to themselves and their loved ones to learn about these developments.

ADEMCO LIMITED WARRANTY

Alarm Device Manufacturing Company, a Division of Pittway Corporation, and its divisions, subsidiaries and affiliates ("Seller"), 165 Eileen Way, Syosset, New York 11791, warrants its products to be in conformance with its own plans and specifications and to be free from defects in materials and workmanship under normal use and service for 18 months from the date stamp control on the product or, for products not having an Ademco date stamp, for 12 months from date of original purchase unless the installation instructions or catalog sets forth a shorter period, in which case the shorter period shall apply. Seller's obligation shall be limited to repairing or replacing, at its option, free of charge for materials or labor, any product which is proved not in compliance with Seller's specifications or proves defective in materials or workmanship under normal use and service. Seller shall have no obligation under this Limited Warranty or otherwise if the product is altered or improperly repaired or serviced by anyone other than Ademco factory service. For warranty service, return product transportation prepaid, to Ademco Factory Service, 165 Eileen Way, Syosset, New York 11791.

THERE ARE NO WARRANTIES, EXPRESS OR IMPLIED, OF MERCHANTABILITY, OR FITNESS FOR A PARTICULAR PURPOSE OR OTHERWISE, WHICH EXTEND BEYOND THE DESCRIPTION ON THE FACE HEREOF. IN NO CASE SHALL SELLER BE LIABLE TO ANYONE FOR ANY CONSEQUENTIAL OR INCIDENTAL DAMAGES FOR BREACH OF THIS OR ANY OTHER WARRANTY, EXPRESS OR IMPLIED, OR UPON ANY OTHER BASIS OF LIABILITY WHATSOEVER, EVEN IF THE LOSS OR DAMAGE IS CAUSED BY THE SELLER'S OWN NEGLIGENCE OR FAULT.

Seller does not represent that the products it sells may not be compromised or circumvented; that the products will prevent any personal injury or property loss by burglary, robbery, fire or otherwise; or that the products will in all cases provide adequate warning or protection. Customer understands that a properly installed and maintained alarm may only reduce the risk of a burglary, robbery, fire or other events occurring without providing an alarm, but it is not insurance or a guarantee that such will not occur or that there will be no personal injury or property loss as a result. CONSEQUENTLY, SELLER SHALL HAVE NO LIABILITY FOR ANY PERSONAL INJURY, PROPERTY DAMAGE OR OTHER LOSS BASED ON A CLAIM THE PRODUCT FAILED TO GIVE WARNING. HOWEVER, IF SELLER IS HELD LIABLE, WHETHER DIRECTLY OR INDIRECTLY, FOR ANY LOSS OR DAMAGE ARISING UNDER THIS LIMITED WARRANTY OR OTHERWISE, REGARDLESS OF CAUSE OR ORIGIN, SELLER'S MAXIMUM LIABILITY SHALL NOT IN ANY CASE EXCEED THE PURCHASE PRICE OF THE PRODUCT, WHICH SHALL BE THE COMPLETE AND EXCLUSIVE REMEDY AGAINST SELLER. This warranty replaces any previous warranties and is the only warranty made by Seller on this product. No increase or alteration, written or verbal, of the obligations of this Limited Warranty is authorized.

INDEX

1

1361 34, 60
1361CN 34

2

24-hour Audible Alarm 12
24-hour Auxiliary Alarm 12
24-hour Silent Alarm 12

4

4+2 Express 50
4+2 Reporting 49
4100SM 5, 45, 48
4130PC 5, 48
4137AD 5, 30, 35, 60
4139SN 16
4142TR 26
 X-10 26
4146 5, 24
4190 35
4190WH 16
4191SN 16
4192CP 16, 35
4192SD 16, 35
4192SDT 16, 35
4194 16, 35
4197 16, 35
4204 5, 26
4208 16, 35
4275 16, 35
4278 16, 35
4280 6, 17, 18, 35
4280 63 35
4280-8 17, 35
4281 6, 18
4281/5881 17
4281H 17
4281L 17
4281M 17
4300 26
464 22
487-12 488-12 31

5

5137AD 5, 7, 30, 35, 60
5700 6
5701 21
5706 21
5707 21
5711 21
5711WM 21
5715WH 21
5716 21
5727 21
5775 21
5800 6, 19
5801 22
5802 22
5802CP 22
5803 22
5806 22
5807 22
5816 22
5817 22
5827 22
5849 22
5881 6, 18
5881H 17
5881L 17

5881M 17
5890 22

6

6139 5, 7, 30, 35, 60
675 23, 35

7

702 32
719 32
740 32
747 32
7720 23
7920SE 23

A

ABB1031 32
AC Loss Reporting 7
AC Outlet Ground 34
Access Control 6, 43
Access Door Control 10
ADEMCO 4+2 EXPRESS 60
ADEMCO CONTACT ID 60
Ademco Contact ID reporting 39
ADEMCO HIGH SPEED 60
Ademco Low Speed 49, 60
Alarm Sounder Duration 9
Alpha Descriptors 7
AMSECO motor bell & box 32
Amseco PAL 328N 25
Arm-Away 12
Arm-Stay 12
Arming Away 42
Arming Functions 42
Arming Instant 42
Arming Maximum 42
Arming Stay 42
ATLIS-BBS 2
Auto-arm 10
AUXILIARY DEVICE CURRENT DRAW
WORKSHEET 35

B

B401B 13
BACK-UP BATTERY 60
Back-Up Power 34
BATTERY STANDBY 34
Built-in Users Manual 6
Bypass 9
Bypassing Zones 42

C

Cabinet 6
Callback 7
CANADIAN DEPARTMENT OF
COMMUNICATIONS 55
Cancel Report 7
CD 45
Check Messages 44
checksum 50
Chime Mode 9, 42
Circuit Breakers 6
CIRCUIT PROTECTORS 60
CLOCK, Real Time
 Setting the 36
Cold Water Pipe 34
Comm. Defaults 7
COMM. FAILURE 52
Comm. Fields 7

Communication 5
Confirmation of Arming Ding 9
CONSOLES

 Maximum wire length 31
 Powering Additional 31
 Programming 31
 Remote 30

CONTACT ID EVENT CODES
 Table of 51

Contact ID Reporting 51
 ADVISORY 51

CTS 45
Custom Words 7

D

Daylight Savings Time 10
DB25 45
Delay Closing Time 43
Descriptors 6
DH400 base 13
DIGITAL COMMUNICATOR 60
DIP SWITCH TABLES 56
DIP switches 18
Disarm 12
Disarming 42
Downloaded Messages
 Viewing 43
Downloading 7
 Direct Wire 48
DSR 45
DTMF 50
DTR 45
Dual reporting 49
Dual Tone Multi-Frequency 50
Duress 9, 37

E

E8 18
Earth Ground Connections 34
EDP printer 45
EEROM 5
End User Scheduling 10
Entry and Exit Delays 9
Entry/Exit 11, 1, 2
EOL 24
EOLR 13
EOLR Fire Zone 13
EOLR Supervised 13, 14
ESL 21
Event Log
 Clearing 47
Event Logging 6
 Display & Print Modes 46
 Printer Connections 45
Event Programming 10
Exception Reporting 7
Exit Delay 9
expanded reporting 49

F

FCC 54
FCC REGISTRATION NO 60
form C 26

G

Glass Break Detector 6
Glass Break Detectors 14
Glass Break Devices 14
Global Arm 42

Global Arming 6, 42
Global Arming Notes 42
Global Disarm 42
Go To 9
Go/No Go 19
Go/No Go Mode 18
GOTO 8, 43
GOTO Function 39
Ground Start 23
Ground Start Module 23

H
HARD-WIRED ZONES 13
High Speed Reporting 50
 Limitations 50
house ID 17, 18

I
IEI 735L 14
Installer 37
Installer Code 7
Intercom Interference 15
Interference Handbook 54
Interior w/Delay 12
Interior, Follower 11

J
J7 45
J8 45

K
Keyswitch 24
kiss-off 49

L
Level 0 37
Level 1 37
Level 2 38
Levels 3-5 38
LIMITED WARRANTY 63
LINE SEIZE 60
Lock, Cabinet
 Mounting the 33
LORRA 7
LORRA Subscriber Radios 23

M
Manager 37, 40
Master 37, 40
Master Codes 39
Max. Zone Resistance 14
 modem 48
MULTIPLE PARTITION ACCESS 39

N
Not Ready 42
NP4-12 34, 60
NP7-12 34, 60

O
Open/close 9, 49
Open/close by exception 10
Operator 38
Operator code 40
Operator level A 37
Operator level B 37
Operator level C 37
Output Control 5, 26

P

PA400 32
PA400B 32
PA400R 32
PABX 32
Panic Keys 5, 9, 12
PART 68 54
Partition Specific Features 9
Partitioning Features
 BASIC 8
PC Board

 Mounting the 33
Perimeter Burglary. 11
Phone Line Connections 32
Phone Numbers 7
Polling Loop 6, 15
 Extending 16
POLLING LOOP ADVISORIES 15
POLLING LOOP CURRENT DRAW
WORKSHEET 35
Polling Loop Extender 16
Power-Up Procedure 34
Primary Subscriber Number 9
Programming 5

Q
Quick Arm 9, 42
Quick Bypass 6

R
RADIONICS LOW SPEED 60
Real-Time Clock 7
 Setting the 36
Relay Control 10
relay modules 10
RELAYS
 Examples of Users 27
Remote Sounder 25
Resistance 13
Response Time 13, 14
RF Receivers 17
RINGER EQUIVALENCE 60
ringer equivalence number 54
RJ31X 54
RPM 15
RS232 45

S
Scheduling 6, 10
Scheduling Menus 7
Secondary Subscriber 9
Serial numbers 18
SESCOA 60
Sescoa/Radionics 49
SET-UP ERROR 18
Smoke Detectors 13, 14
Sniffer Mode 17
SOUNDERS
 Compatible 32
 External 32
Spatial Diversity 18
SPECIFICATIONS 60
Split reporting 49
Split/Dual Reporting 7, 49
STANDBY CURRENT DRAW 34
SUMMARY OF CONNECTIONS 61
Supervised Fire 12
Swinger Suppression 9
SYSTEM FEATURES
 SUMMARY 5
System Sensor 21

System Sensor 1400 13
System Sensor 1451 13
System Sensor 1451DH 13
System Sensor 2300T 13
System Sensor 2400 13
System Sensor 2400TH 13
System Sensor 2451 13
System Sensor 2451TH 13

T
TECHNICAL SUPPORT
 CONTACT 2
test 49
Test Mode 52
Test Reporting 7
time windows 10
TouchTone 50
Transmitter ID 18
Transmitters 19
Trouble by Day/Alarm by Night 11
Trouble Conditions 44

U
UL INSTALLATION REQUIREMENTS 54
UL installations 13
UL NOTE 7
UL1023 60
UL609 60
Unsupervised 13, 14
User Codes 5, 7, 9, 37, 38
 Adding a Master Manager or
 Operator 40
 Changing a Master Manager or
 Operator 40
 Deleting a Master Manager or
 Operator 40
 General Information 37
User's Manual
 Using the Built-In 43

V
Voltage Triggers 7, 23

W
Wireless 6
 Advisories 20

X
X-10 5, 10, 26

Z
Zone 1 13
Zone 1 Advisories 13
Zone 9 13
Zone 9 Advisories 13
ZONE CONFIGURATION 11
Zone Reports 7
Zones 2 - 8 14
Zones 2-8 Advisories 14



4140XMPT2-INST 5/93 (part of N5944-2)

ALARM DEVICE MANUFACTURING CO.
A DIVISION OF PITTMAY CORP.
165 EILEEN WAY, SYOSSET, NY 11791

COPYRIGHT © 1993 PITTMAY CORPORATION